

INSPIRATION SERIES



■ OPERATING INSTRUCTIONS

Ergoline

Ergoline

1004003-00- / us / kn / 03.2008

OPERATING INSTRUCTIONS

USA

CDN

Inspiration 400 Turbo Power VHP12

Inspiration 450 Turbo Power VHP12

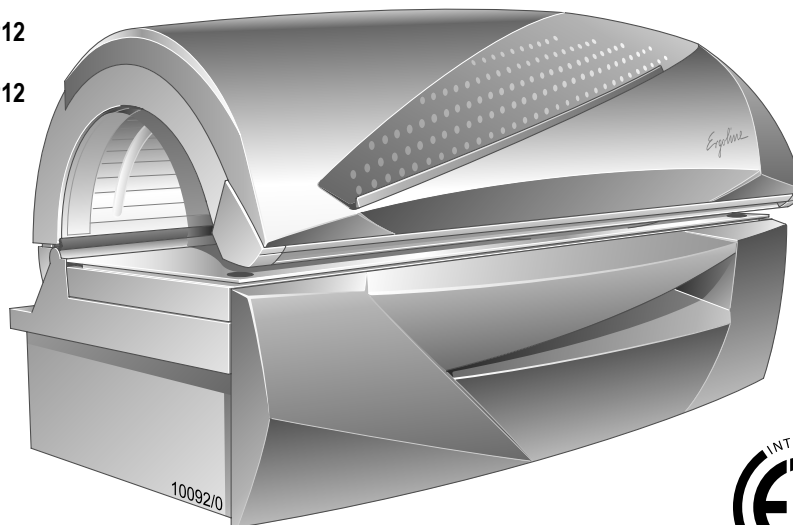

Identify your tanning device

For contact with Customer Services, please write down the device number of your tanning device.

--	--	--	--	--	--	--

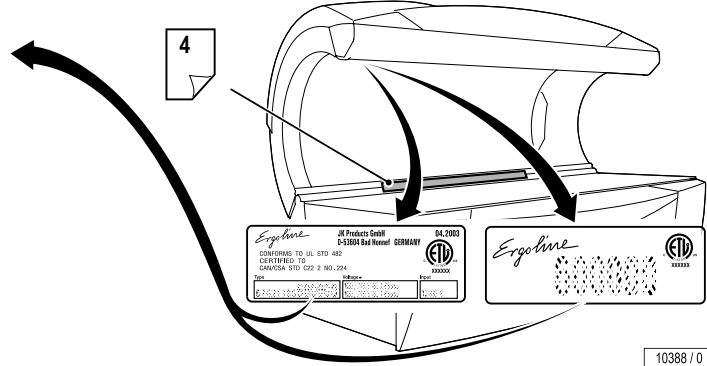
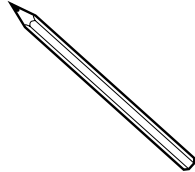

Global Service USA
A Div of JK Products & Services, Inc.
#1 Walter Kratz Drive
Jonesboro, AR 72401



☎ 800-445-0624
☎ 870-935-9046

e-mail: support@jkamerica.com
<http://support.jkamerica.com>

Skin types

For the recommended exposure schedule see page 4.

Skin type I (Sensitive):

Invariably gets sunburn, accepts little natural sunlight and does not tan.

Skin type II (Fair):

This is the individual that usually burns easily and severely, tans minimally or lightly and peels.

Skin type III (Average):

Often referred to as "Average" complexion, burns moderately and tans about average.

Skin type IV (Brown):

This individual burns minimally, tans easily and above average with each exposure.

Skin type V (Dark Brown):

This individual's system rarely burns, tans easily and substantially.

Tanning times

DANGER ULTRAVIOLET RADIATION		Recommended Exposure Schedule					
Follow instructions. Avoid over-exposure as with natural sunlight. Over-exposure can cause eye and skin injury and allergic reactions. Repeated exposure may cause premature aging of the skin and skin cancer.		Skin Type	Week 1 1st - 3rd Treatments	Week 2 4th - 6th Treatments	Week 3 7th - 10th Treatments	Week 4 11th - 15th Treatments	Weekly Subsequent Treatments
Maximum Tanning Time is 12 Minutes		I - Sensitive	NOT ADVISED	NOT ADVISED	NOT ADVISED	NOT ADVISED	NOT ADVISED
		II - Fair	2 Min.	5 Min.	8 Min.	10 Min.	12 Min.
		III - Average	2 Min.	5 Min.	8 Min.	10 Min.	12 Min.
		IV - Brown	2 Min.	7 Min.	10 Min.	12 Min.	12 Min.
		V - Dark Brown	2 Min.	7 Min.	10 Min.	12 Min.	12 Min.

WEAR PROTECTIVE EYEWEAR! Failure to do so may result in severe burns or long term injury to the eyes.

Certain medications or cosmetics may increase your sensitivity to the ultraviolet radiation. Consult a physician before using sunlamps if you are using medication, have a history of skin problems or believe yourself to be especially sensitive to sunlight. If you do not tan in the sun, you are unlikely to tan from the use of this product.

This unit utilizes UVA lamps. Replace only with **Ergoline VHP 12 160W Turbo Power (1,80m)**, **Ergoline VHP 12 180W Turbo Power (2,00m)** and **JK Ergoline 400W F100723 (high pressure)** or recognized equivalents. To obtain recommended exposure at a minimum distance of 1/2" (13mm) measured with a standard ruler, lie on acrylic surface of lounge and lower canopy. Canopy will stop at the correct distance from lounge acrylic surface.

Warning: The use of any other position may result in overexposure!

Tanning can begin on a regular basis. An appearance of tanning normally appears after a few exposures and maximizes after four (4) weeks of exposure following the recommended exposure schedule for skin type. In order to provide for maintenance of a tan a maximum of two (2) weekly 12 minute sessions is recommended from the fifth week onward.

Do not tan more than once in a 24 hour period.

Use protective eyewear (Part No. Schmerler 2255 Red or recognized equivalents) when equipment is on. Read and follow instruction booklet before using this product. To avoid electrical shock during maintenance disconnect power from unit.

Part No: 1005418-00-



Note:
Description of skin types see
Page 3.

10616 / 0

"This product is in conformity with performance standards for sunlamp products under CFR21 Part 1040."

Table of contents	7
General safety instructions and information	9
Description	19
Operation	22
Maintenance	51
Technical data / appendix	89
Index	101



Dear Customer,

The Ergoline device you have purchased is a technically advanced and powerful product. Your device was manufactured with the greatest care and precision. It went through numerous quality and safety checks in order to guarantee trouble-free, safe operation. Nonetheless, you can also make a significant contribution to your long-term satisfaction with your device. Following the tips and instructions in the instruction manual will ensure you enjoyment and pleasure with your device.

If you have any questions, we are always available to answer them.¹⁾

Yours sincerely

JK-Products, Inc.

- Please read and follow the instructions in this operating manual carefully. This will help prevent accidents and ensure that your sunbed is always fully functional and operational.
- Always comply with generally accepted legal provisions and any further directives and statutory regulations, as well as any environmental protection requirements in force, including those of the country in which the system is operated.
- Always comply with local regulations in force established by professional associations and other regulatory authorities.

1) ☎ (800) 643 0086

Table of contents

Use the sunbed – but use it properly!	4	Operation	
Skin types	5	Mandatory reading	22
Tanning times	6	Operation overview	23
Important safety notes	9	Tanning	25
Safety notices	9	Use the sunbed – but use it properly!	25
Instructions pertaining to a risk of fire, electric shock, or injury	10	Start of tanning	26
Instructions pertaining to a risk of damage to the machine	12	Interrupt or end tanning session	27
Product information acrylic glass panels	18	Regulating the facial tanner	28
Meaning of symbols	13	Switching air condition off and on	31
Intended use	16	Regulating body cooling	33
Obligations of the studio operator	16	Switching AROMA on and off	35
Guidelines	16	Switching AQUA MIST on and off	37
Export	16	MP3 player connection	39
MP3 music (optional)	17	Voice Guide	41
Product information acrylic glass panels	18	Listening to Info texts	43
Environmental protection information	18	Selecting the audio system (channel)	45
		Adjusting the volume and switching-off the audio systems	48
		Running time of accent lights	50
Description			
Equipment	19		
Description	20		
Accessories	21		





Maintenance	Index	101
Maintenance overview		
54		
Cleaning and maintenance intervals	Customer information	144
58		
Relamping / maintenance instructions		
63		
Cleaning/replacing UV low-pressure lamps in the sunbed base	Presettings – see “Presettings”, Order No. 1001971	
64		
Cleaning/replacing UV low-pressure lamps in the canopy	Troubleshooting – see “Error codes”, Order No. 800751	
67		
Cleaning/replacing interior lighting		
70		
Cleaning or replacing UV high-pressure lamps and filter panels in the canopy	Timer operation – see manual “Intellitan Remote Timer”, Order no. 801129	
73		
Cleaning/replacing accent light in front panel		
76		
Cleaning the base filters		
78		
Air condition: Emptying the condensation tank and cleaning the filter .		
80		
Replacing the AROMA tank		
84		
AQUA MIST system: Replacing the canister		
86		
Technical data		
Connected load, power and noise level		
89		
Rated power, activation and power levels of the UV lamps		
90		
Installed lamps		
91		
Spare parts and accessories		
94		
Dimensions		
95		
Installation location		
96		

Important safety notes

Safety notices

Description of warning signs

Danger notices, damage to persons:



DANGER!

Type and source of danger, e.g. “DANGER – High voltage!”

Description of the consequences, e.g. “You can be killed or injured by an electric shock!”

Countermeasures:

- Disconnect device from power supply before opening.
- Do not reach into the inside with the device switched on.

Warning notices, damage to persons:



WARNING!

Type and source of danger, e.g. “Warning – hot surface!”

Description of the consequences, e.g. “You can burn your hand (skin, face)!”

Countermeasures:

- Do not touch hot parts and nearby surfaces.
- Wait until hot parts and surfaces have cooled down.

Caution notices, damage to property:



Caution!

The word “Caution” with this label points out that danger for devices, materials and the environment can be expected here.

Important information:



Note:

This symbol does not identify safety notices, but states information for a better understanding of the processes.



Instructions pertaining to a risk of fire, electric shock, or injury



DANGER!

DANGER – High voltage!

You can be killed or injured by an electric shock!

Assembly and electrical connection must comply with national and local regulations.

- The device may only be assembled, installed, upgraded or repaired by specially trained and instructed personnel.



WARNING!

WARNING – ultraviolet radiation!

Unprotected tanning may result in eye injury and eye diseases.

The unprotected eye can become inflamed on the surface, and in certain cases the retina can be damaged by excessive radiation. Cataracts can form after frequently repeated exposure to radiation.

- **Inform users to use the included protective goggles that block UV** (Order No. 84592-...).



WARNING!

WARNING – ultraviolet radiation! Follow instructions!

Failure to use protective eyewear may result in severe burns or other eye injury. If discomfort develops, discontinue use and consult a physician.

- A person who does not tan in the sun most likely will not tan from the use of this device. Persons with very sensitive skins (skin type I) must not use the unit, as with this skin type tanning is impossible without damaging the skin (e.g. sunburn).
- Individuals with acute sunburn, individuals who have had or have skin cancer, or individuals who are at increased risk of skin cancer, must not use the system.
- UV devices must not be used without taking medical advice if unexpected effects, such as itching, occur within 48 hours of the first session.
- The sunbed must never be used if a filter panel is missing or damaged, or the timer is defective!
- UV light from the sun or UV systems can cause injuries to the skin or eyes. This biological effect is dependent on the sensitivity of the individual's skin and on the type and amount of UV light.
- As with natural sunlight, overexposure can cause eye and skin injury, sunburn, and allergic reactions.



WARNING!

- Repeated exposure may cause premature aging of the skin and skin cancer.
- Medications or cosmetics applied to the skin, may increase sensitivity to ultraviolet light.
- A person having a history of skin problems should consult a physician before use.



WARNING!

WARNING – ultraviolet radiation!

Danger of long-term consequences.

- Overexposure should be avoided.
- The elderly should not use this equipment.
- Nursing infants and small children through age 7 years may not use this device.
- The following applies to minors under the age of 18 years: Only use tanning devices in agreement with a parent or guardian, or after consulting a physician.
- While there is no immediate clinical evidence of UVA exposure and its effects upon expectant mothers, it is strongly advised that expectant mothers be discouraged from using the tanning unit.



WARNING!

WARNING – risk of infection!

Infections can be transferred through skin contact.

All items/equipment components, with which the user can come into contact during tanning, must be disinfected after every tanning session:

- Protective goggles
- Acrylic sunbed
- Handles and control panel
- MP3 cable

For fast, hygienic proper cleaning, use a specially developed fast disinfectant cleaner.





Note:

Occasionally, persons using the tanning device will experience a slight reddening of the skin – usually in small patches – after the second or third session. This redness is often accompanied by an itching sensation. This may be nothing more than a heat “rash” caused by heat from the lamps within the device. It is generally very limited and caused by constant contact of the skin with the acrylic surface. It should go away within approximately 24 hours and should not reappear. This rashing can be lessened or prevented by applying moisturizer lotion to the affected area after the tanning session is completed.

- Follow instructions.
- The time between the first two tanning sessions must be at least 24 hours.
- Increasing tanning also requires an extension of the exposure time (= radiation time) or after a certain degree of tanning has been achieved, a further intensification is not possible. However, the radiation time may not be extended as desired within the scope of the permissible radiation doses! Therefore, only a certain degree of final tanning dependent on the skin type can be achieved without endangering your health.
- Inform users about proper tanning.

Instructions pertaining to a risk of damage to the machine



















CAUTION – danger of overheating!

Danger of overheating by obstruction of the air routing.

- Do not change, obstruct or block the air inflow and outflow area to the device or make any unauthorized changes to the device. The manufacturer shall bear no liability for damage or injuries resulting from such actions.
- Before putting a tanning device into operation, the transport pallet must be removed from under the device. Danger of overheating by obstruction of the air routing.

Information for the studio operator

Meaning of symbols

	Inform Customer Services		Filter panels
	Ergoline key		Cleaning and disinfectant agents
	Do not touch, hot surface!		Part/item number (for orders)
	Suction cup		Display of tanning time
	Low-pressure lamp(s)		Display of run-on time (fan run-on)
	UV low-pressure lamp(s)		Fault display (example), see separate manual
	Starter for low-pressure lamp(s)		Display of Info Track 1 (from 1-17)
	UV high-pressure lamp(s)		Display of Music Channel 1 (Channel 1) Factory setting: 1 channel Customer service can set up to 7 channels



Information for the studio operator



	Display when adjusting volume		Headphone connection
	Description		Caution, safety switch!
	Accent lights		Two persons are required for this work step.
	Body cooling with AQUA SOLAR WITH SKIN+ ADDITIVE		Unscrew/release screw
	Fragrance (AQUA MIST AROMA system)		Tighten/lock screw
	Press button		Cleaning
	Press button for 2 seconds		Replacing
	Duration: 3 minutes		Clean or replace depending on soiling
	Loudspeaker		Draining

Information for the studio operator



Air condition



Visual inspection



Filter/filter mat



Filter and filter mats must not be damp.



Continuation of work steps on next page



End of work step



Intended use

The tanning device is intended exclusively for cosmetic tanning of the human skin.

- The device is meant for commercial use only, not for home use.
- This device is used for tanning one adult person at a time.
- The user wears suitable eye protection that blocks UV radiation during tanning.

Any other use shall be considered improper. The manufacturer cannot be held liable for damage or injuries resulting from this. The operator bears the sole risk for this.

The proper use also includes compliance with the manufacturer's instructions, operating and maintenance conditions. This device may only be operated, maintained and repaired by persons familiar with these tasks and who have been informed of the dangers involved.

Obligations of the studio operator

- As the operator you are responsible for informing users on possible risks during tanning.
- All danger and safety labels attached to the device must be observed! Do not remove them!
- No safety equipment (e.g. panel switch) may be removed or deactivated which can impair the safe operation of the device!
- The device may only be operated in a serviceable condition!
- The operator is bound to ensure that the equipment is handled correctly.

Guidelines

This device was built conforming to UL STD 482, and is certified to CAN/CSA STD C22.2 2 No. 224.

Export

We would like to point out that these devices are exclusively intended for use in the USA and Canada and may not be exported to other countries and operated there! The manufacturer assumes no liability whatsoever in the event of non-compliance! We explicitly emphasize that high liability risks may occur for the exporter and/or the operator in the event of non-compliance.

MP3 music (optional)

The personal use of an MP3 player during tanning is **not** a public broadcast in copyright terms, so that there is no obligation for registration or payment by the studio owner to the corresponding copyright owning company in respect of copyright exists on the part of the studio operator.

The same regulations apply for the official use of MP3 music files as for other music sources: As studio owner you are only allowed to use original audio CDs, MCs, audio DVDs etc. in your premises and / or play them in the MP3 music module fitted to the Ergoline professional sunbed if you have already obtained the corresponding performing rights.¹⁾

Copy-protected audio CDs, MCs, audio DVDs etc., as well as the tracks included on these media, are not allowed to be converted to MP3 format and / or stored on hard discs, audio CDs, MCs, audio DVDs etc. when software and / or computer programs are used for this purpose which cancel or avoid the copy-protection included on the storage media.

At the request of the external staff or any other controlling body of the responsible company, you must always be in a position to prove that you have purchased the performance rights by showing the relevant authorisation.

As long you follow the advice given above and have gained of the necessary rights, you may convert your original audio CDs, MCs, audio DVDs etc. to the MP3 format required for the player. However, you may only create one copy (either a duplicate or a conversion to MP3 format)

for each audio CD, MC, audio DVD etc. for which you have obtained the legal rights. The original sound storage medium must be stored and is not allowed to be used at the same time.



1) from the company responsible for the allocation of commercial performing rights in your country (in Germany: GEMA/GVL)

Product information acrylic glass panels

The acrylic glass panels for the tanning devices are produced of acrylic glass developed especially for this application. The acrylics used are characterized by a particularly high UV permeability and resistance, as well as an easy-care, hygienic surface that is gentle to the skin.

The acrylic glass panels are formed to their shapes for the specific devices in a technically complex production process. Despite state-of-the-art production know-how, the presence of minor spots, air bubbles or streaks in the acrylic panels is unavoidable. In addition, microfine hairline cracks can occur on the bed surface during operation.

These occurrences are material-dependent and are unavoidable in processing, however have no significant effect on the use or value and can therefore not be recognized as defects.



CAUTION!

Cosmetics or sun screen products must be removed prior to using the sunbed as they can cause damage (e.g. fine cracks on the surface) when used continuously.

Environmental protection information

Environmental Declaration – The JK Corporate Group

The JK corporate group is subject to the strict regulations of EC Directive 761/2001 and the ISO 14001 standard, and undergoes regular internal and external environment audits performed by trained auditors.

Environmental regulations – disposal of lamps

UV low-pressure lamps and UV high-pressure lamps contain fluorescent materials and other waste containing mercury.

According to the national waste disposal laws and in accordance with the municipal waste regulations, proof must be provided of the proper disposal of UV lamps.

Your local environmental agency will be happy to assist you with the disposal of UV lamps.

Packaging

All packaging consists of 100 % recyclable materials.

Disposal of recyclable materials

The device has been produced of recyclable materials. When being scrapped later, the device must be disposed of properly. Sun Ergoline will provide you with information on the content or potential hazards of the materials used.

Equipment

Depending on the model, each device is equipped differently.

This instruction manual covers all standard and optional components/ functions to be taken into consideration during operation and/or maintenance.

The control panel also differs according to the various equipment: the only visible buttons are those that can be operated, i.e. the corresponding function must be part of the device's equipment.

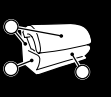

Description

1. Facial tanner (UV high pressure lamps)
2. UV low pressure lamps, base
3. Partition
4. Acrylic cover, base
5. Infrared interface
6. UV low pressure lamps, canopy
7. Interior lighting
8. Body cooling air nozzles
9. AQUA MIST nozzle
10. Face cooling air nozzles/AROMA
11. Control panel
12. Accent lights, canopy
13. Accent light, front panel

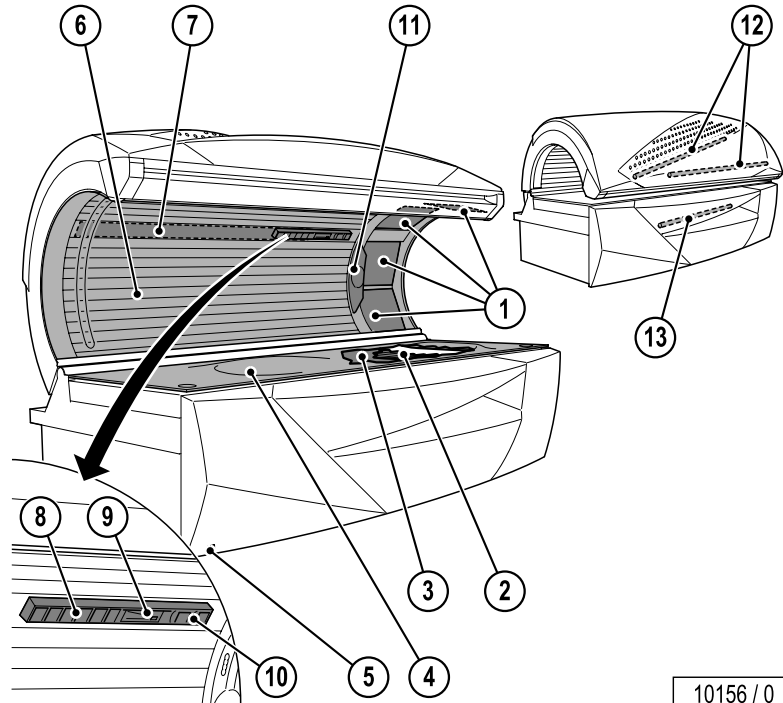

10156 / 0

Accessories

14. Central air discharge socket

15. Audio-system with Voice Guide, 2 loudspeakers

15.1. Headphone connection

15.2. MP3-connection

Some accessory parts are taken into account in the maintenance schedule beginning on page 58 and in the spare parts section from page 94. However this does not automatically mean that your device is fitted with this equipment.

Order numbers and more accessories are listed in the sales documentation and the planning manual.

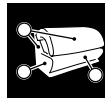
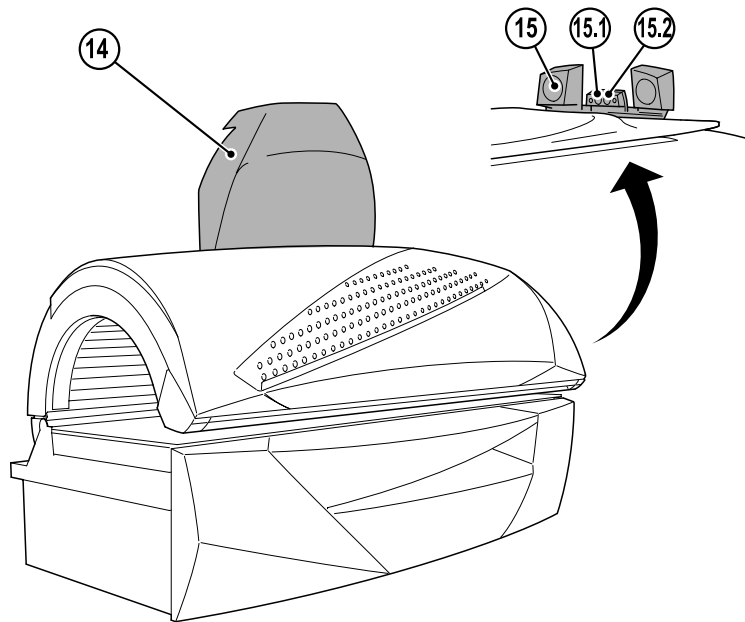

10157 / 0

Operation

Mandatory reading

Always read and follow all instructions for proper usage prior to allow anybody using a tanning device. The operating instructions included with this device must always be followed to prevent possible injuries or to reduce them to a minimum.

Inform users

- to use provided UV-blocking protective eyewear whenever the equipment is energized.
- to follow the exposure schedule in accordance with their skin type. Failure to do so may result in overexposure.

A tanning system is not a toy. You cannot vary the strength of the lamps in your unit.

Should you have any questions regarding the proper use of your tanning system, contact Global Service USA at:

 800 445 0624

7:00 a.m. to 7:00 p.m. (CT)



WARNING!

Warning – ultraviolet radiation!

Danger of skin injuries and skin diseases!

- The sunbed must never be used when a filter panel is missing or damaged, or the timer is defective!



Note:

When describing the operation, the tanning device is often shown with the canopy open. During tanning the canopy must always be closed.

Proper operation is not possible with the canopy open.



Operation overview

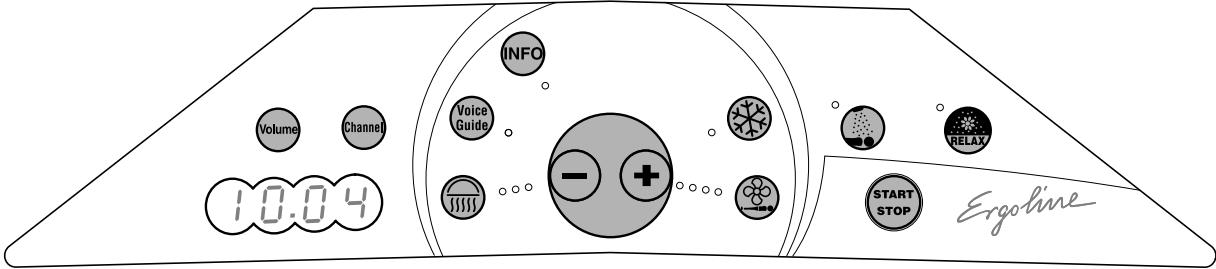

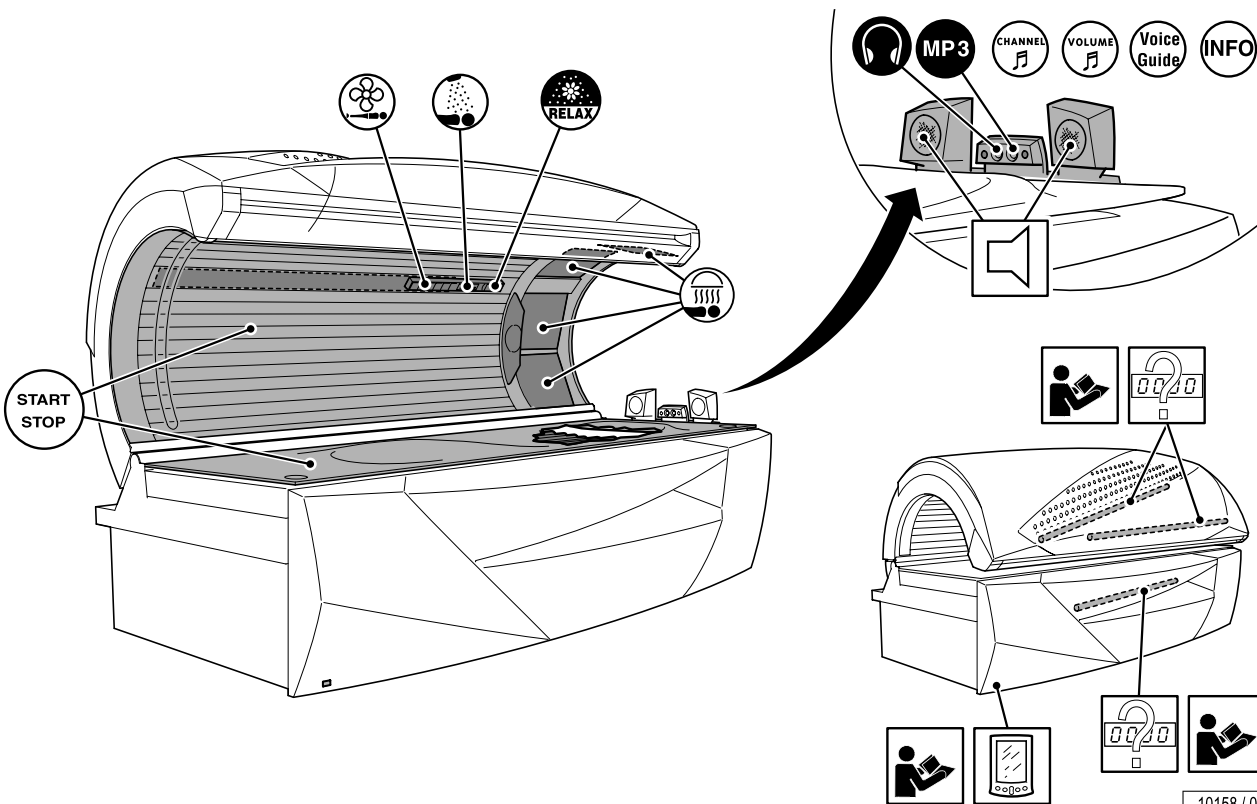

Tanning

Use the sunbed – but use it properly!

A few things need to be noted to get maximum enjoyment from a sunbed. Here are some answers to some frequently asked questions.

Make-up on the sunbed?

Please remove make-up or don't use make-up while tanning. Clean skin absorbs UV light better.

A wide variety of ingredients are found in cosmetics. Again, whether these are emulsifiers, greases, or so-called scents – in conjunction with UV radiation, these can cause allergic reactions of the skin.

Accordingly, a must before using a sunbed is: Remove all make-up. This is essential. Make-up clogs the pores in the face. The UV light from a sunbed re-opens these clogged pores so that not only does the light penetrate the skin, but also the allergenic components of the make-up.

A further negative consequence of make-up is that the appearance of the skin deteriorates irreversibly over a period of time. However good a decent make-up might be – in conjunction with UV light, it causes more harm than good. Therefore: Remove all make-up before a session on your sunbed – it will be much better applied afterwards.

Showering after leaving the sunbed?

The browning is in the skin, not on it. Therefore you cannot wash it off. Treat your skin to a moisturizing cream after showering.

Are medications and the sunbed compatible?

It is known that some medications increase the skin's sensitivity to UV light. This probability is particularly high with antibiotics, sulphonamides, psychiatric drugs, tranquilizers, anti-diabetes treatments and diuretics. Sun creams which contain psorale or kumarin also increase skin sensitivity. If you are in any doubt, first ask your doctor - then you can enjoy the sun at no risk.

Contact lenses on the sunbed?

The answer is: Yes! Like any other sunbed user, contact lens wearers should also wear special protective goggles which protect the eyes against UV radiation. To guarantee better protection, wearers of spectacles and contact lenses can ask their optician for exchange contact lenses with UV protection. The UV-A and UV-B filters built into exchange contact lenses will protect the cornea and the internal parts of the eye against almost 100% of the energy in UV radiation.

This will benefit sunbed users not only in the open air, but on the sunbed itself. For more information, ask your optician or optometrist.



...

Use the sunbed – but use it properly!

Start of tanning

The device is started automatically with an internal or external timer.



Note:

Timer instructions: see separate manual¹⁾.

Preparation time

Before the UV lamps turn on, you have a few minutes to prepare yourself. During the preparation time you can switch on the UV lamps at any time by pressing the START/STOP button.

- Remove your clothes and all jewelry.
- Remove make-up and other cosmetics.
- Remove glasses. Contact lenses can be worn under the protective goggles.
- Put on the protective goggles.
- Lie down on the bed surface.
- Close the canopy.
- Press the START/STOP button.



Closing the canopy

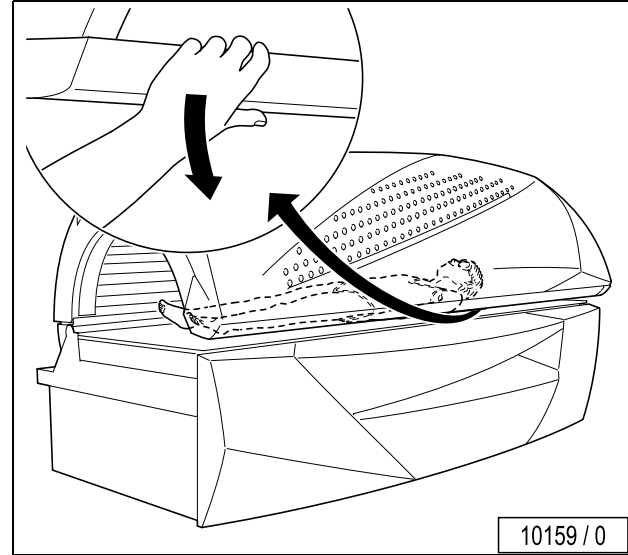

1) Order no 801129-..



Use the sunbed – but use it properly!

Interrupt or end tanning session

The tanning session ends automatically after the preset time has run down. The internal fan continues to run for approx. three (3) minutes to sufficiently cool the device.

- To interrupt a tanning session, press button START/STOP anytime during a session.
- Press START/STOP again to restart the lamps.

Settings on start-up

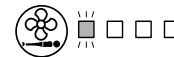
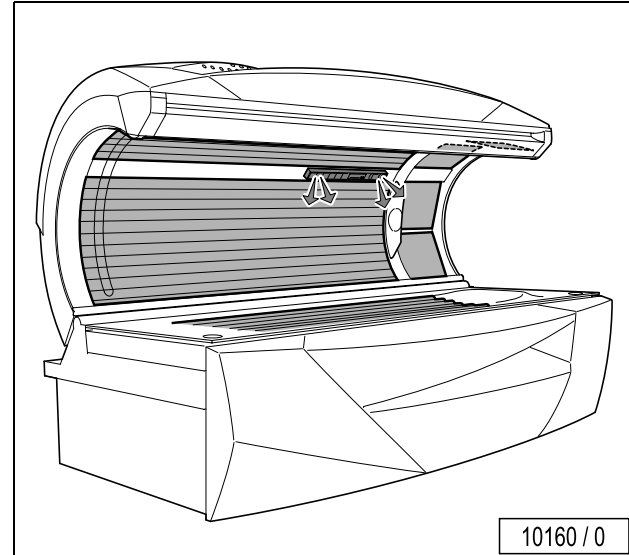

optional:



Regulating the facial tanner



Switching the facial tanners OFF:

- Press button  for two (2) seconds.

Switching the facial tanners on again:

- Press button . It takes approx. one (1) minute until the facial tanners reach their full output.

Adjusting the intensity:

- Press button .
- While the button  flashes, press + or - to adjust the intensity of the facial tanners.

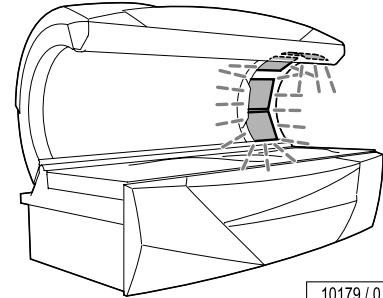

10179 / 0

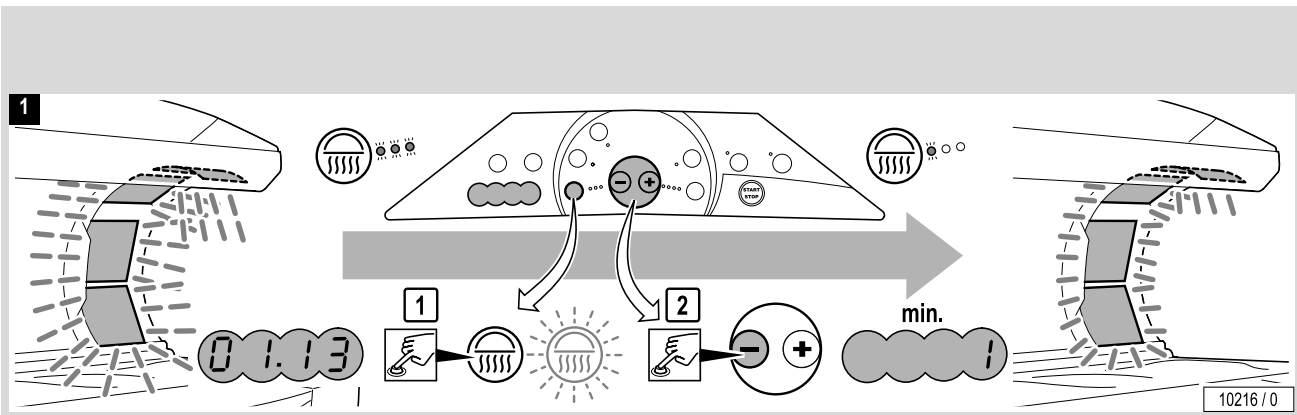

10216 / 0

...

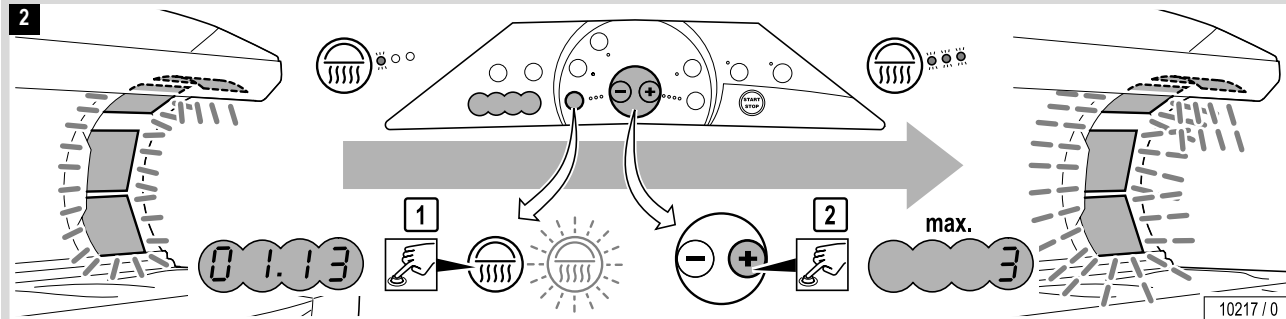

STOP: Press for two (2) seconds.

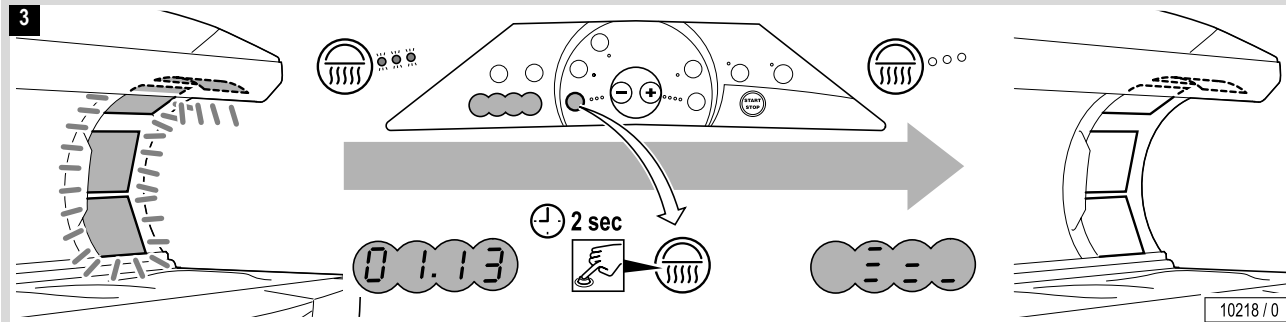

START

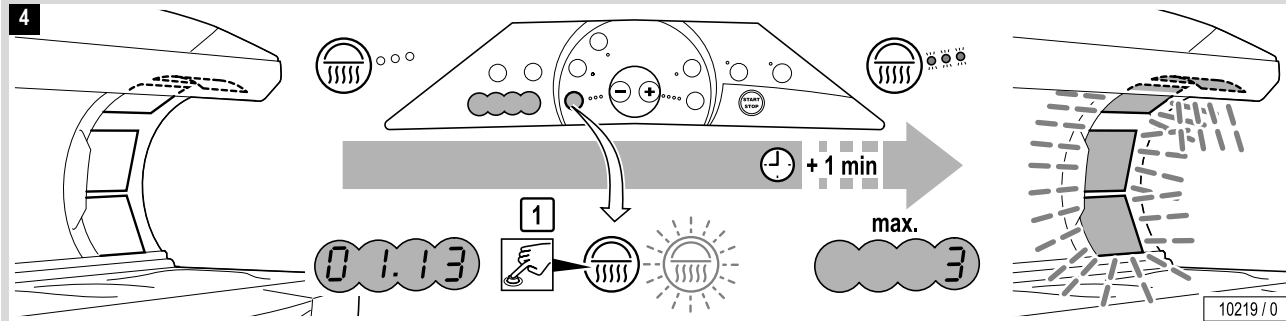

10219 / 0



Switching air condition off and on

Inspiration Turbo Power

Switching air condition OFF:

- Press button  for 2 seconds.

Switching air condition on again:

- Press button  again. It takes approx. 3 minutes until the cooling effect of the air condition is reestablished.

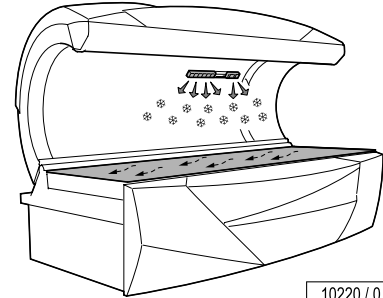

10220 / 0

STOP

1

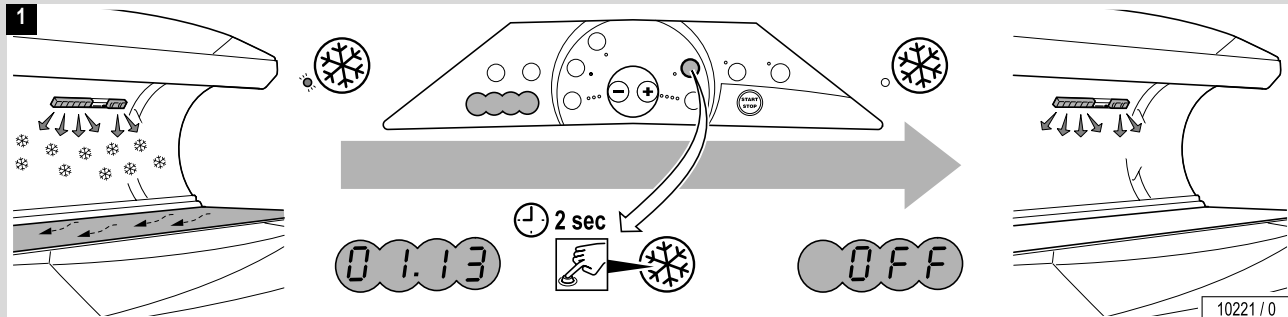

10221 / 0



Switching air condition off and on

START

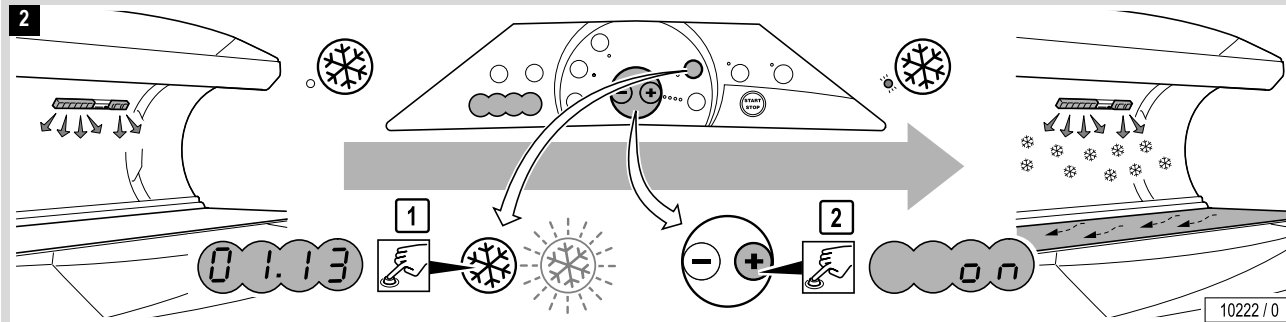

Regulating body cooling

- Press button .
- While the button flashes, press the plus or minus button to change the intensity of the air stream.

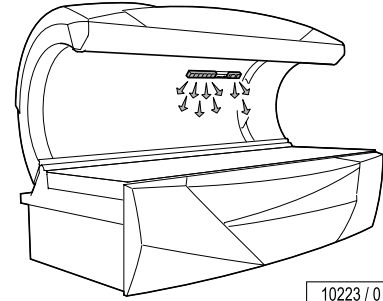

10223 / 0

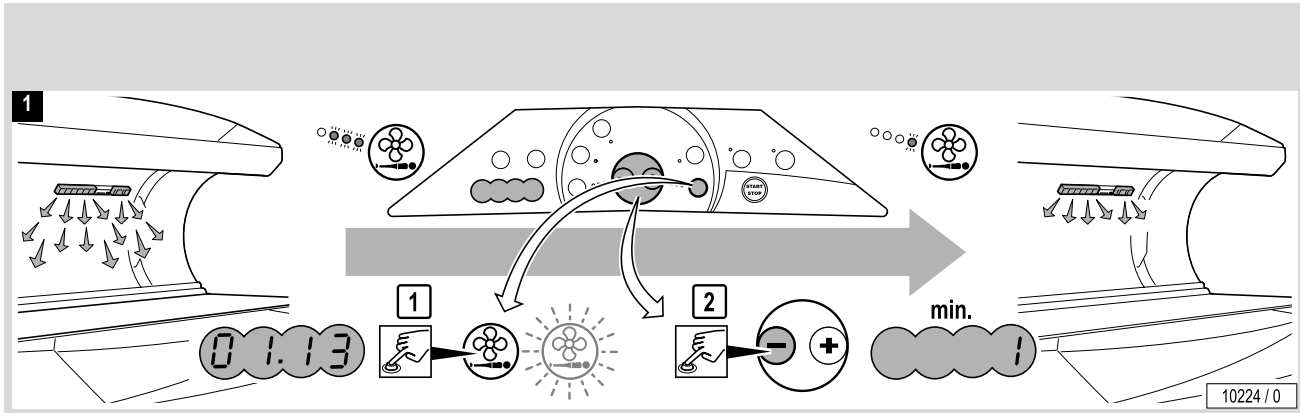

Regulating body cooling

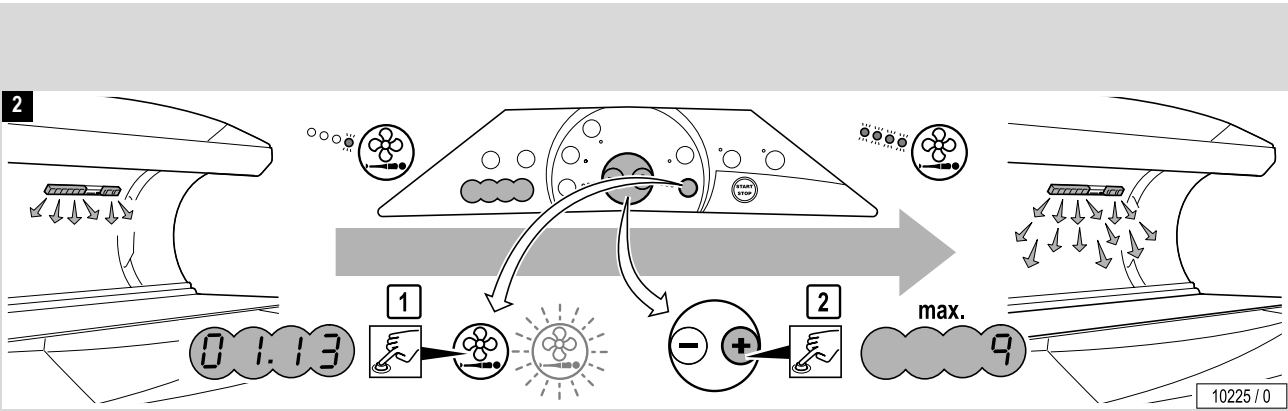

Switching AROMA on and off

Inspiration Turbo Power

Switching AROMA on:

- Press button .

Switching AROMA OFF:

- Press button  again.

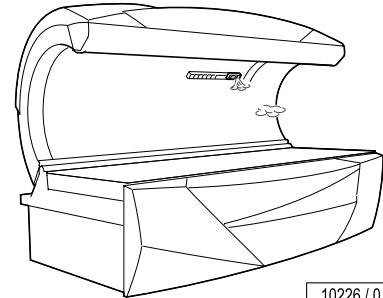

10226 / 0

START

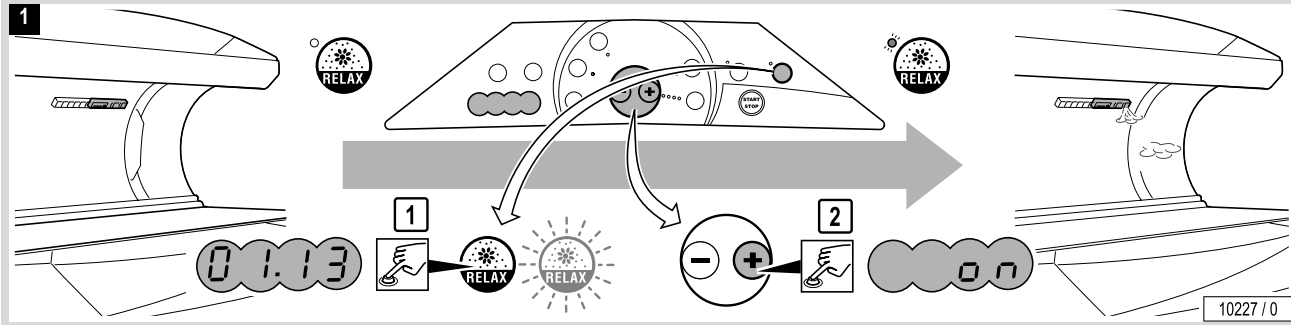

Switching AROMA on and off

STOP

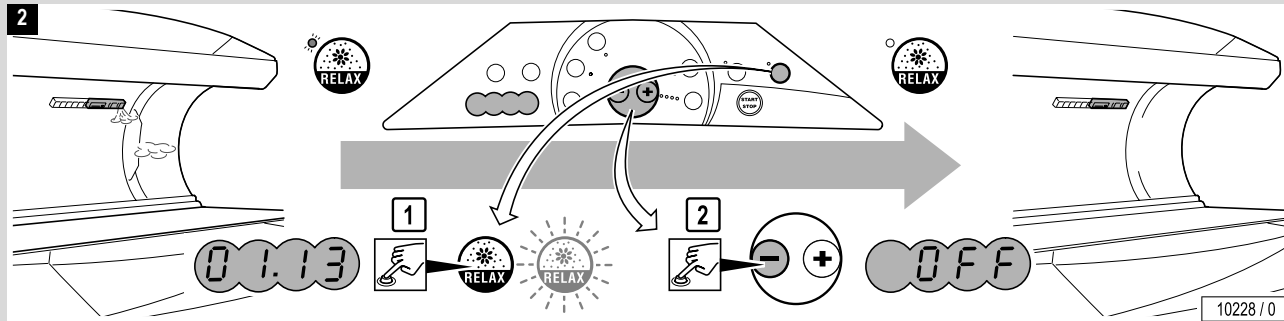

Switching AQUA MIST on and off

Inspiration Turbo Power

Switching AQUA MIST on:

- Press button .

Switching AQUA MIST OFF:

- Press button  again.

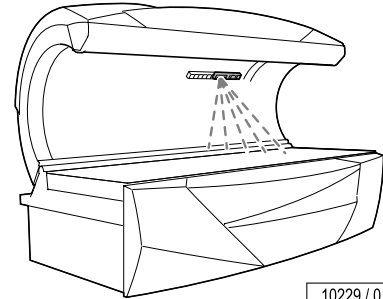

10229 / 0

START

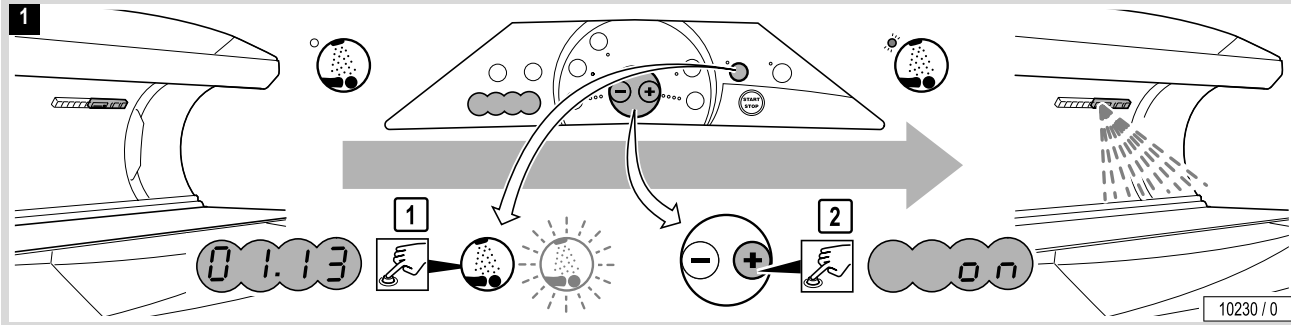

Switching AQUA MIST on and off

STOP

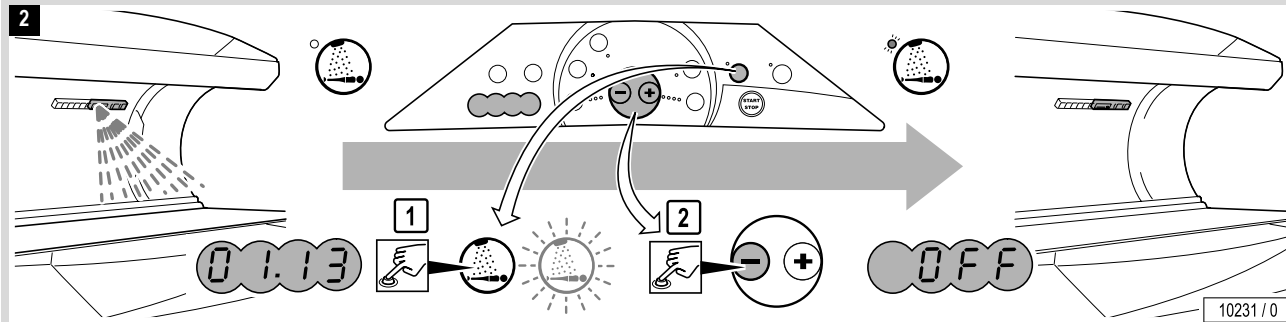

MP3 player connection

Studio customers can connect their own MP3 player to the device when the “Audio System” accessory is available.

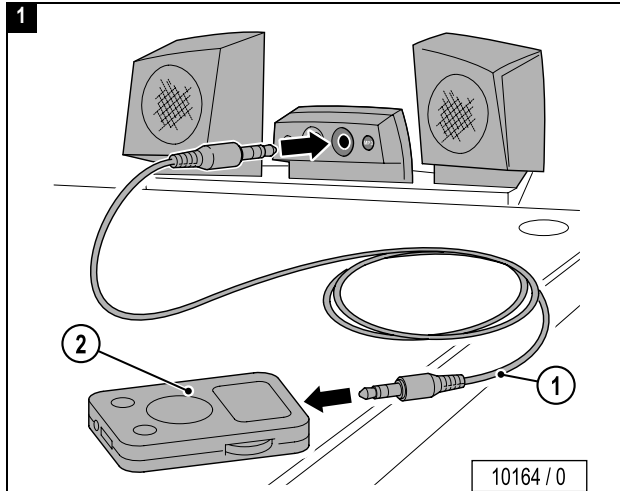

- ① Jack plug (Mat.-Nr. 1001855-..) provided for use by the studio operator (1.5 m / 2 x 3.5 mm stereo jack plug).
- ② MP3 player connection: refer to the manufacturer’s documentation.

Loud music might disturb other studio users!

- Use headphones whenever necessary.

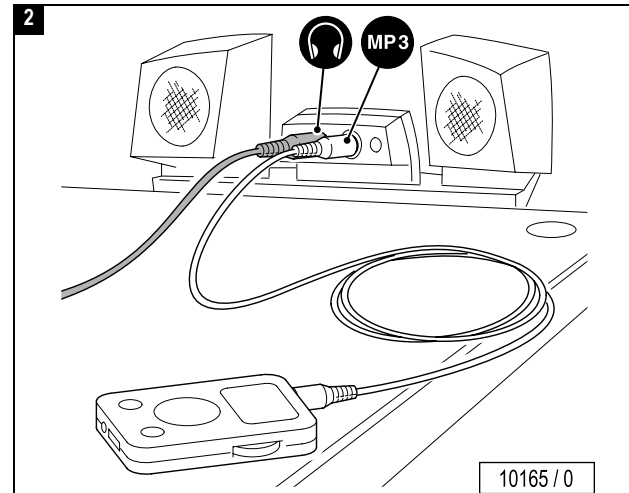



Caution!

The heat might damage your MP3 player.

- Do not position the unit so that it receives direct tanning radiation.

Cable may be torn off, connectors may be damaged.

- Do not pull on cable when unplugging MP3 player.

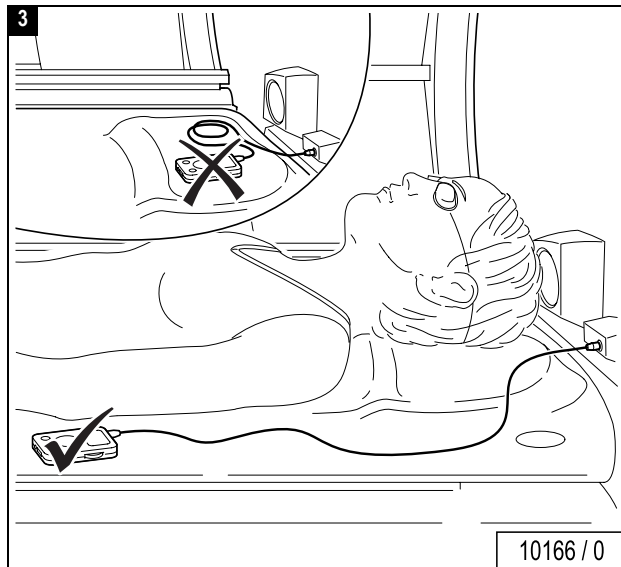

Voice Guide

Voice Guide gives acoustic guidance when operating the device and is only available in conjunction with the audio system.

Voice Guide is activated by default during both stand-by and a tanning session.

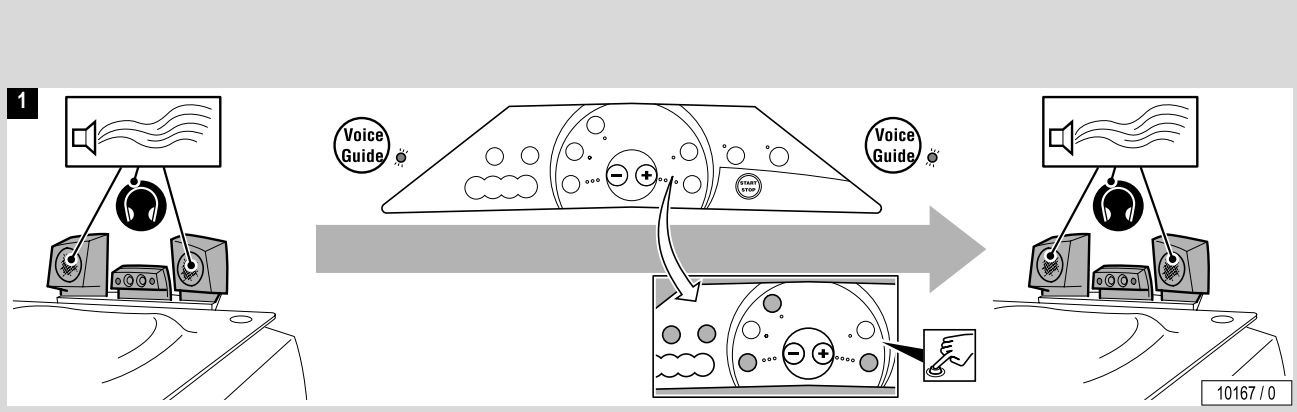
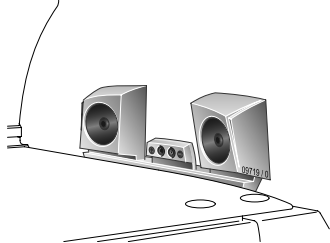

STOP

2

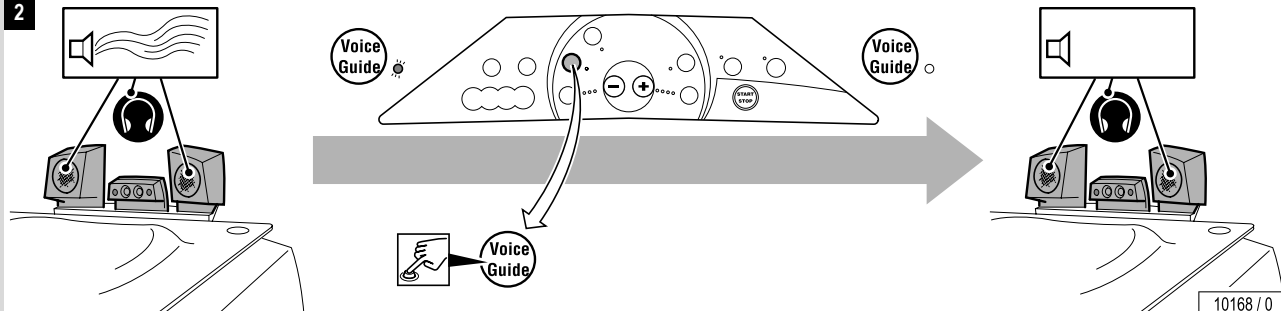

START

3

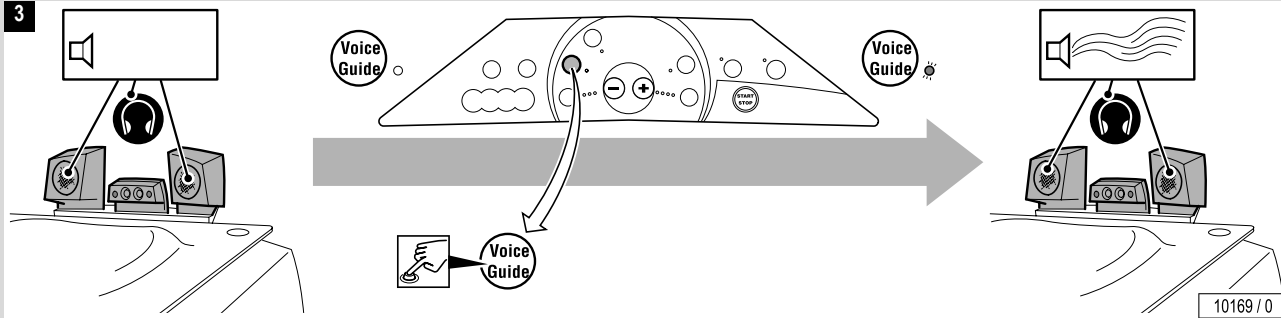

Listening to Info texts

General information about the sunbed.

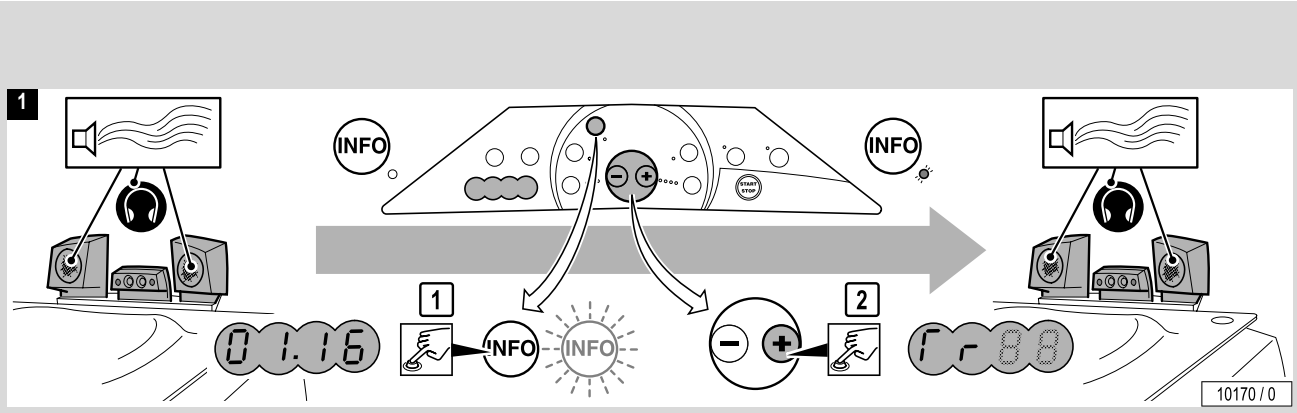
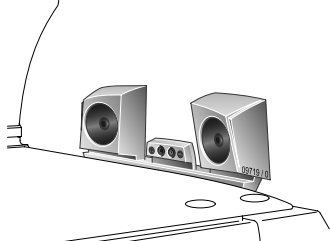

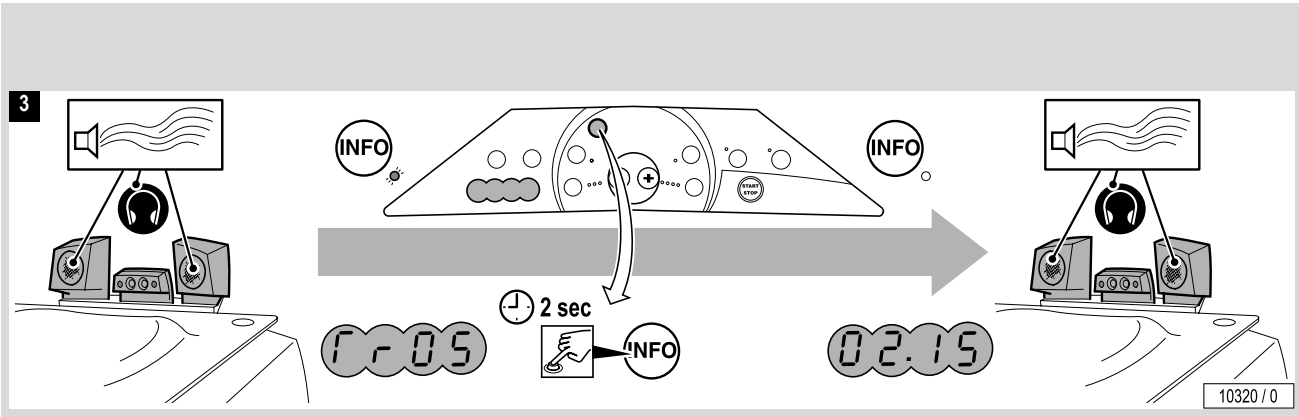
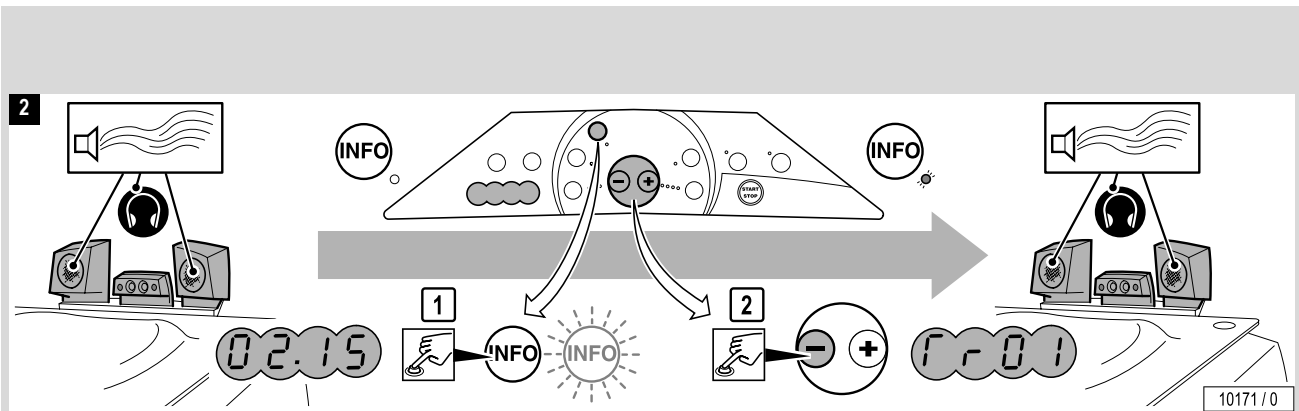

Selecting the audio system (channel)

I.CH (internal): SD card "music"

E.CH (external): externally connected systems (e.g. CD-player)

P.3: MP3 player

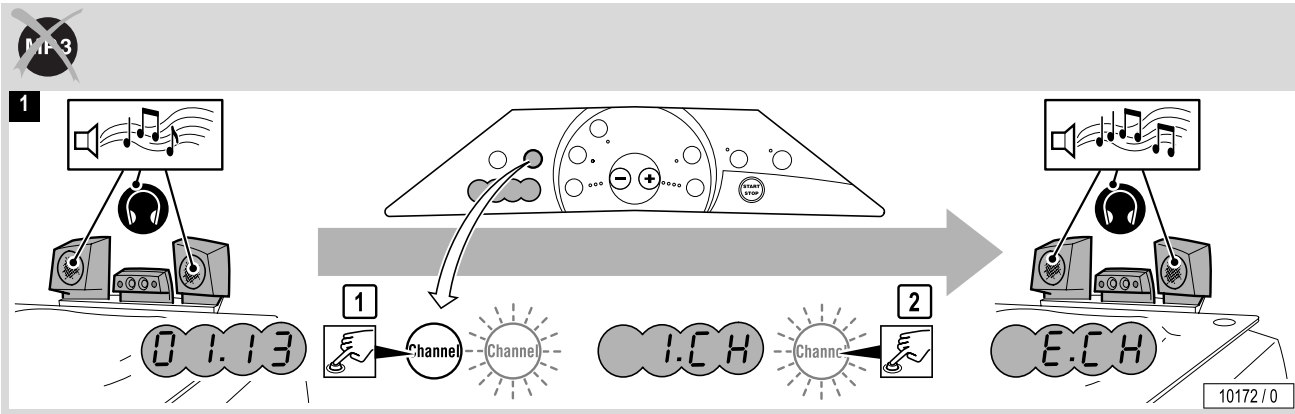
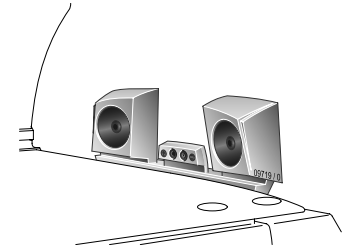

Selecting the audio system (channel)

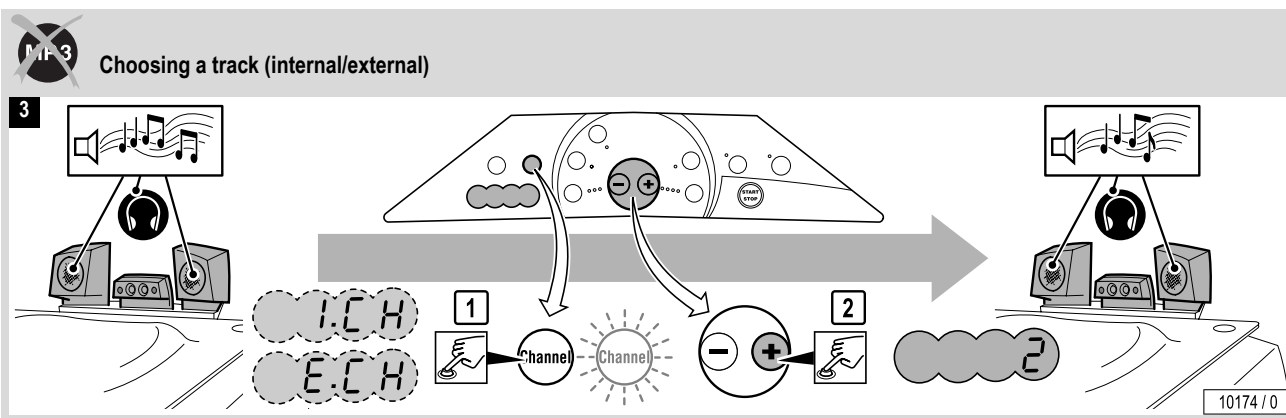
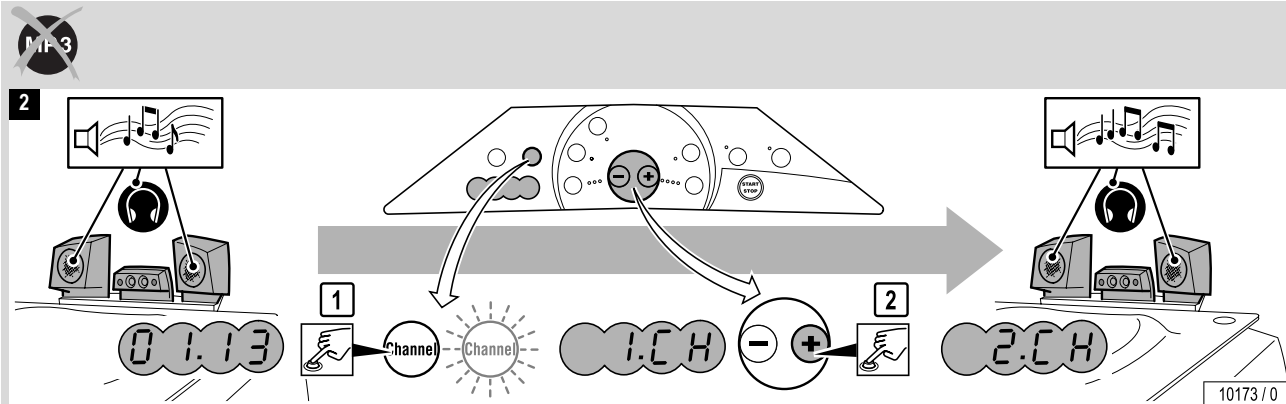

Selecting the audio system (channel)

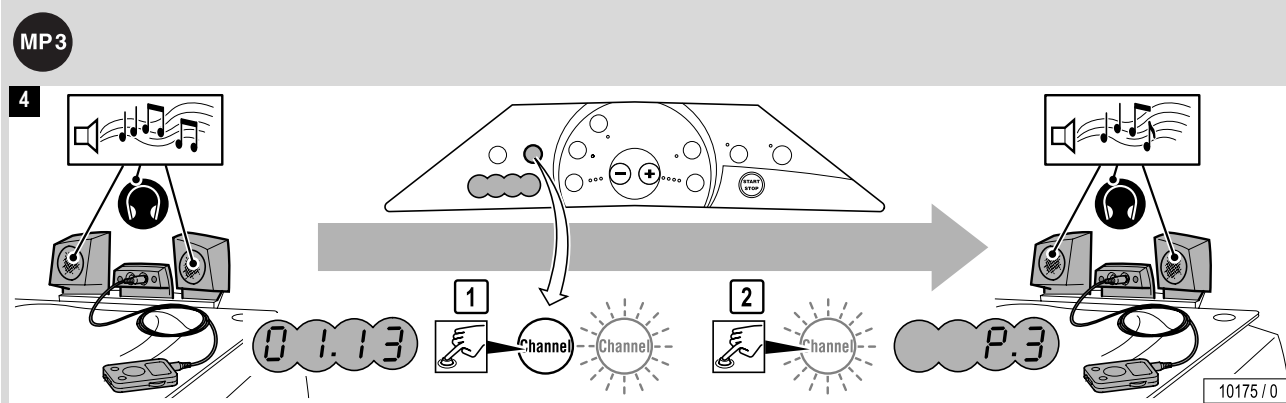

Adjusting the volume and switching-off the audio systems



Risk of hearing loss!

- With time, the human ear becomes accustomed to high sound levels.
- The higher you adjust the volume, the quicker the hearing can be damaged.
- The use of ear pieces and headphones at high volume can lead to permanent hearing loss.



Maximum

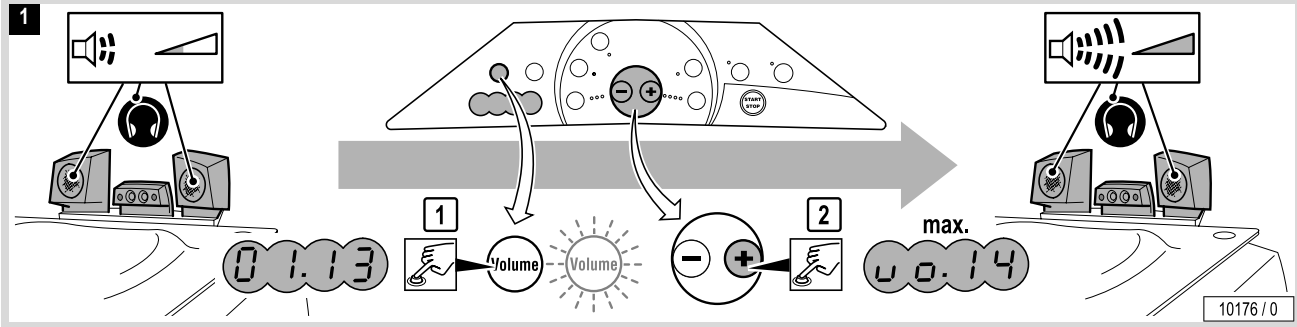

Adjusting the volume and switching-off the audio systems

Minimum

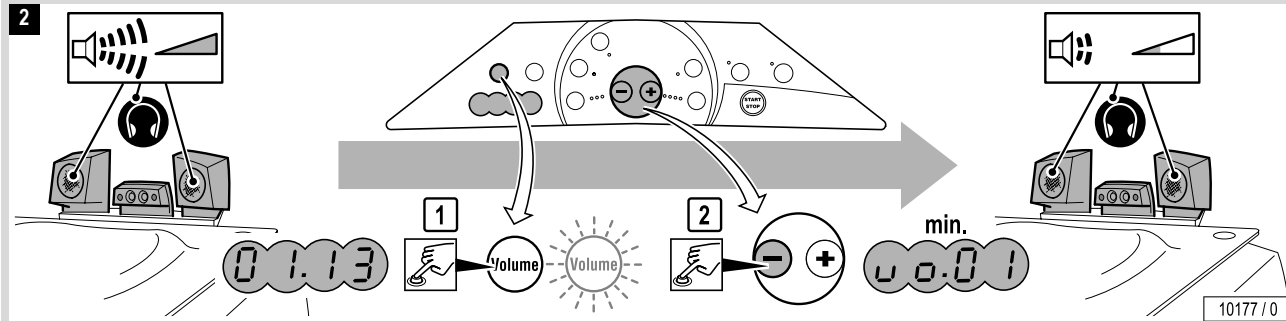

OFF

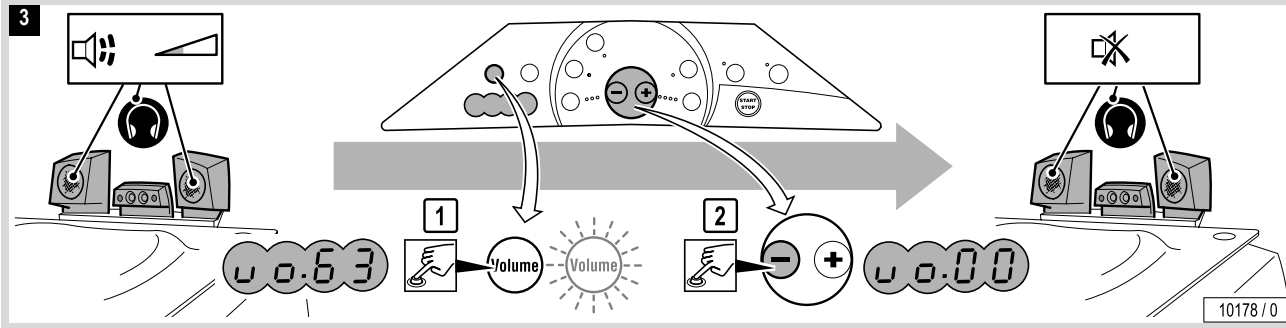

Running time of accent lights

The accent lights are automatically switched on at the end of the tanning session after the set operating time and are switched off again at the beginning of the next tanning session.

The running time of the accent lights in the Standby mode can be changed with the presettings – see separate instructions.



Stand-by

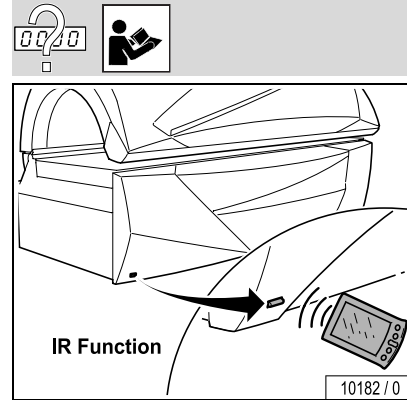
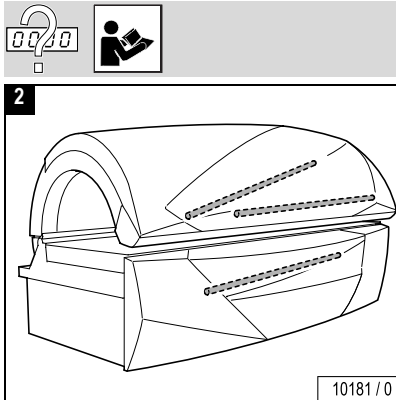
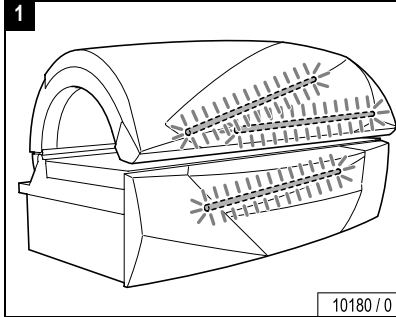

See separate instructions "Presettings", Order no. 1001971



Safety information for maintenance and care



Extreme danger! High voltage!

During maintenance work there is a risk of touching live parts and receiving a fatal electric shock.

- Disconnect device from power supply before opening – also see Page 52.
- Do not reach behind covers and do not open the device with the device switched on.
- Refit any safety devices (e.g. switches) after the work has been completed.

Maintenance and care play a major role in deciding whether the device meets the requirements placed on it in a satisfactory manner. The compliance with the specified maintenance intervals and the careful conducting of the maintenance and care work are therefore absolutely necessary – see Page 58.

The current operating hours of the parts requiring maintenance can be displayed in the Presetting mode – see separate instructions “Presettings”, Order no. 1001971.



Danger of burns!

Only use the specified **genuine UV lamps and filter panels!**

Using other UV lamps leads to modified radiation. This could potentially result in severe burns to the user!

The use of other UV lamps and filter panels invalidates **CE conformity** and the **GS approval mark!**



CAUTION!

Only use **genuine** spare parts of the same type!

The use of other parts may limit or void your manufacturer's warranty!

Any liability is excluded in case of damage or injury proven to be the result of the use of non-genuine spare parts.



Fire hazard!

High-pressure lamps that have not been approved by Ergoline can explode. Hot lamp components can set other components on fire. People can be killed or severely injured due to smoke inhalation and fire.

- Only fit high-pressure lamps recommended by Ergoline.
- Clean the inside of the tanning device regularly. Dust-particles are combustible!

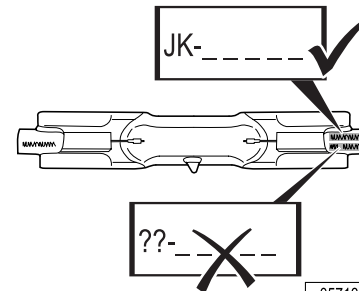

05713 / 0



...

Power Off device and secure against being switched on again



Extreme danger!

If work is to be performed on the devices, they must be powered off. That means that all live lines must be switched off. Switching off the device alone is insufficient, as certain points may remain energized. Therefore, switch off and lockout circuit breakers before performing any work.

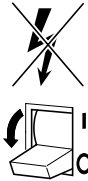

04049 / 0



Extreme danger!

Severe accidents can occur if the device is mistakenly switched on again. Immediately after powering off, secure all switches or fuses used for power against being switched on again.

- A strip of adhesive tape with the wording "DANGER do not switch ON!" may be applied over the actuation levers of circuit breakers which cannot be removed.

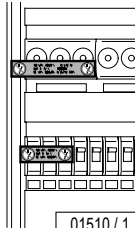

01510 / 1

A prohibition sign with the text: "Work in progress!"

- "Place:"
- "Sign may only be removed by:" must always be securely mounted immediately.



01511 / 1



Extreme danger!

Prohibition signs must not be hung on or touch live parts.

Malfunctions

The display shows error codes¹⁾ to make it easier to localize the cause of the problem.

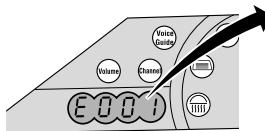

Fehlercode	Störung/Fehlerbeschreibung	Abhilfe
E 0 0 1	Kondensatbehälter voll (Fehleranzeige nur möglich bei Original-Kondensatbehälter.)	Kondensatbehälter leeren
E 0 0 2	Störung Kondensatpumpe	
E 0 0 3	Überdruckschalter Klimagerät (Gerätekühlung)	
E 0 0 4	Druckwächter +B24 Klimadruck überschritten	
E 0 0 5	Temperaturfühler Climatronic (Klimagerät)	
E 0 0 6	Temperaturfühler Climatronic (Klimagerät)	
E 0 0 7	Warnung Betriebsstunden Filter Klimagerät überschritten	Filtermatten prüfen und ggf. reinigen, danach Laufzeit der Filtermatten im Voreinstellungsmodus zurücksetzen
E 0 1 0	Temperaturbegrenzer Gesichtsbürste	

10389 / 0

- If a malfunction occurs, the error code flashes in the display.
- If several malfunctions occur, the error messages are displayed alternately.
- The fault remedy is acknowledged by holding down the **START/STOP** button.
- If the problem cannot be remedied, inform Customer Service – see Page 2.

1) See separate instructions "Error Codes", Order no. 800751

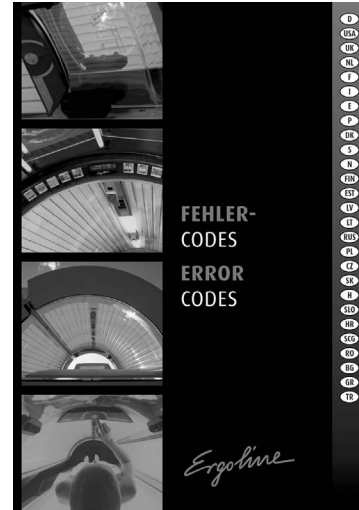

800751

10391 / 0



Maintenance overview



see separate instructions "Presettings", Order no. 1001971

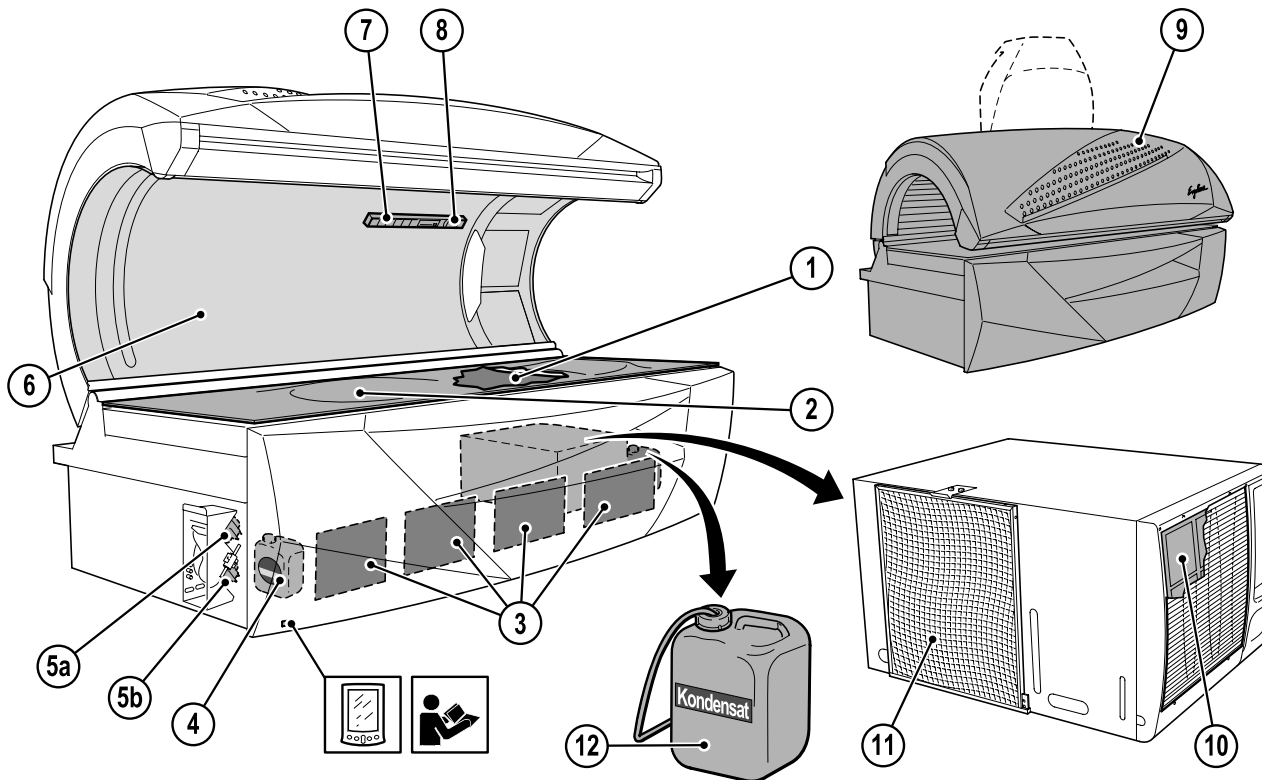

10183 / 0



Cleaning

Acrylic glass surfaces



CAUTION!

Do not rub with a dry cloth – danger of scratching!

For fast, hygienic proper cleaning of acrylic glass surfaces, use a specially developed fast disinfectant cleaner.

Other cleaning agents, especially concentrated disinfectants or solvents (e.g. Lysoform, ethyl alcohol or other liquids containing alcohol) must never be used for cleaning.

Failure to observe this voids all warranty claims.

Plastic surfaces

For cleaning the other plastic surfaces, it is best to use warm water and a leather cloth. Never use aggressive cleaning agents containing alcohol or essential oils. These may lead, in the long run, to damage not covered by the warranty.

During cleaning, a slight discoloration of the leather cloth by the rubber seals must be expected for production-related reasons.



Note:

Prevent damage to plastic surfaces. Remove rings, watches, bracelets etc. before the start of cleaning work.

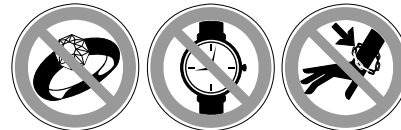

02756 / 0



...

Filter and filter mats



Filters in the sunbed base, in the air conditioner

Dry cleaning: vacuum cleaner (depending on the degree of soiling)

Moist cleaning: water and detergent, or dishwasher.

Air intake openings in the canopy

Dry cleaning: vacuum cleaner

Moist cleaning: water and a mild detergent.



Caution! The system can be damaged by moisture!

The cleaned filters must be dry when re-assembling.



Caution! Risk of damage to the device!

Regularly check the filter grille, filter and cooling fins on the air conditioning system and clean as necessary – see Page 113.

For cleaning the cooling fins we recommend using our special fin comb, Order No. 15720470.



Cleaning filter panes and lamps

The UV high-pressure lamps fitted are broadband radiators which can be operated at different outputs (approx. 240-520 W).

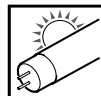

UV low pressure lamps: Clean with water only (damp cloth)

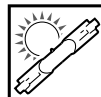

UV high pressure lamps: Clean jackets with methylated spirits if necessary.

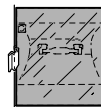

Filter panes: Clean with water only (damp cloth)



Maintenance

AQUA MIST

The AQUA MIST function sprays a fine mist of AQUA SOLAR WITH SKIN+ ADDITIVE into the tanning chamber.



Health hazard for your customers!

Water contaminated with bacteria can cause skin rashes and other allergic reactions in sunbed users.



– Do not, therefore, fill the AQUA MIST canister with tap water or other liquids.



– Only replace the AQUA MIST canister with a genuine canister.



– Do not add any leftovers from the old canister to the new canister.

– Ensure that the specified maximum temperature is not exceeded during transport and storage.

– Note the expiry date on the canister.

AROMA

The AQUA MIST AROMA system also includes fragrances, which are distributed via the head nozzles.

The aroma “Cabin” is distributed in the cabin.



Note:

Alternatively further fragrances are available. More information is available from JK-Licht GmbH.

Acrylic covers

The acrylic covers for the sunbeds are produced of acrylic glass developed especially for this application. The acrylics used are characterized by a particularly high UV permeability and resistance, as well as an easy-care, hygienic surface that is gentle to the skin.

The acrylic covers are formed to sunbed-specific shapes in a technically complex production process. Despite state-of-the-art production know-how, the presence of minor spots, air bubbles or streaks in the acrylic panels is unavoidable. In addition, hairline cracks can occur on the acrylic glass panel during operation.

These occurrences are material-dependent and are unavoidable in processing, however have no significant effect on the utility value and can therefore not be recognized as defects.



Caution!

Cosmetics or sun screen products must be removed prior to tanning as they can cause damage (e.g. fine cracks on the surface) when used continuously.



Cleaning and maintenance intervals

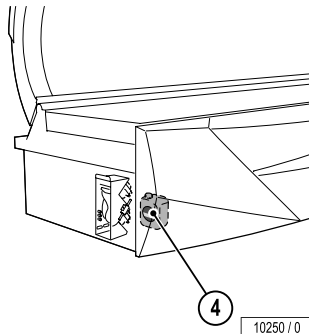
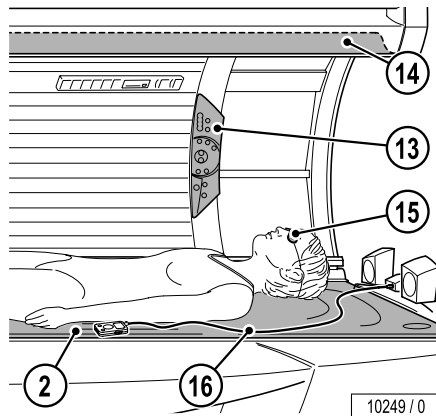

After each tanning

②				55
⑮		Schmerler 2255 Ergoline 84592		55
⑬				55
⑯		1001855		55
⑭				55



Confirm cleaning by pressing the START/STOP button (when the follow-up time of the fan in the device has finished).

Intervals



Intervals, see
"PRODUCT INFORMATION
AQUA SYSTEM"
(order no.: ▲ 801610-..).



...

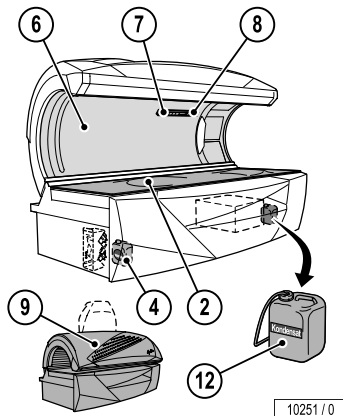

10251 / 0

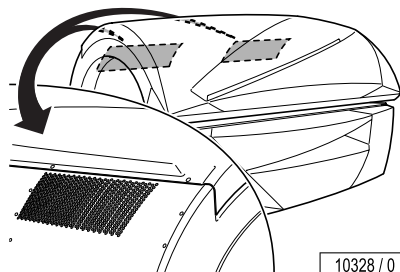

10328 / 0

② - ⑨				55
④				86
⑫		Empty		80

Air intake openings



Fire hazard!

Fluff is inflammable! Regularly remove fluff in the air intake area.

- Use a vacuum cleaner to prevent fluff getting inside the unit.

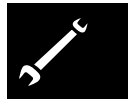

...

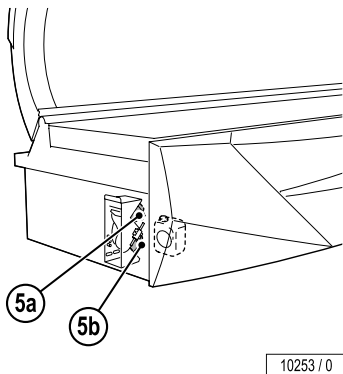
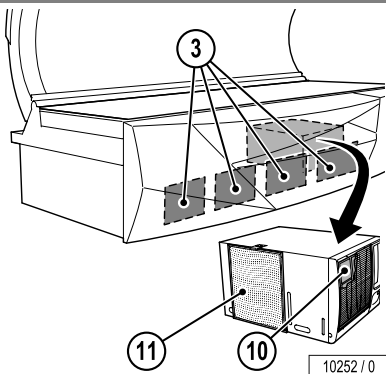

50 h

③			 78
⑩			 80
⑪			 80

300 h

⑤	a)  b) 		 84
---	--	---	--

...

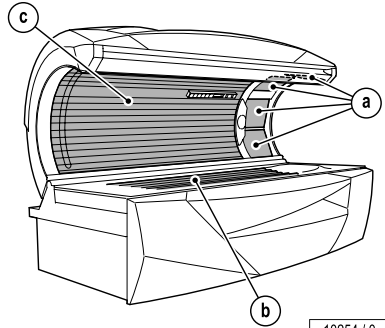

10254 / 0

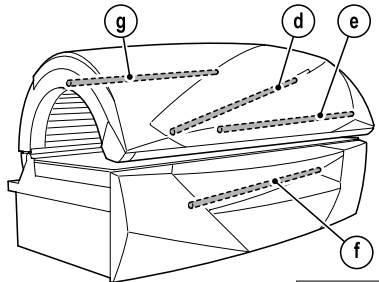

10255 / 0

500 h



a)			☞ 73
b)			☞ 64
c)			☞ 67

1000 h



b) c)			☞ 64, 67
f) g)			☞ 76, 70



...

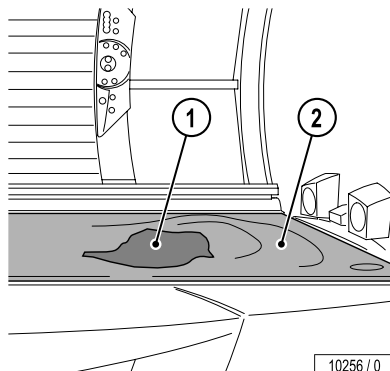

1500 h 

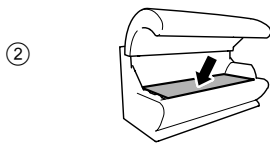

3000 h 

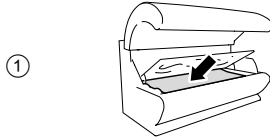

 73

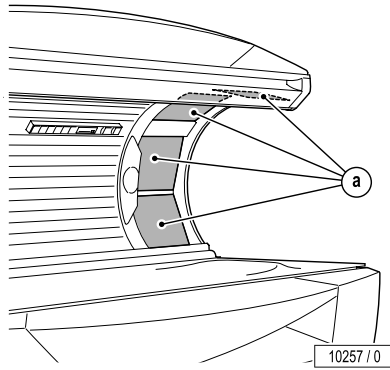

Relamping / maintenance instructions

It is imperative that you, the owner and/or operator, check all components for any signs of wear which may occur through normal use.

Observe the cleaning and maintenance schedule specified in the maintenance table on Page 58 to 62.

Only replace UV low-pressure lamps with the original lamp type or with compatible lamps.

Only replace UV high-pressure lamps with the original lamp type or with compatible lamps.

Should you require any assistance or need additional information, please call Global Service USA at 800 445 0624, Monday through Friday 7:00 a.m. - 7:00 p.m. CT, Saturday 8:00 a.m. to 3:00 p.m.



CAUTION – Damage due to improper maintenance!

Improper maintenance can cause the device to be damaged or to become unusable.

- Always comply with the specified maintenance intervals.
- Follow the cleaning instructions.
- If the maintenance intervals for the UV lamps are exceeded or incompatible UV lamps are installed, the share of harmful UVB radiation may increase. Sunburn and other skin damage may result.



WARNING!

Danger of burns from hot lamps and device parts!

WARNING!

If the tanning device was operated before being switched off and opened, lamps and housing parts may be hot.



- Before replacing lamps or other spare parts, wait until lamps and metal parts of the device have cooled down sufficiently.



Danger of pinching!

When opening and closing the tray, panels and covers, you can pinch your fingers.



Cleaning/replacing UV low-pressure lamps in the sunbed base

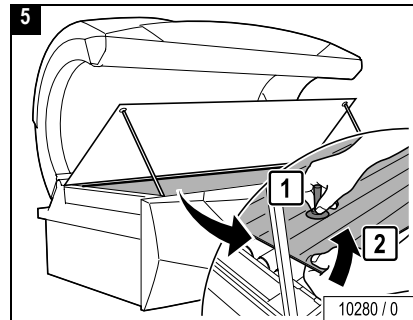
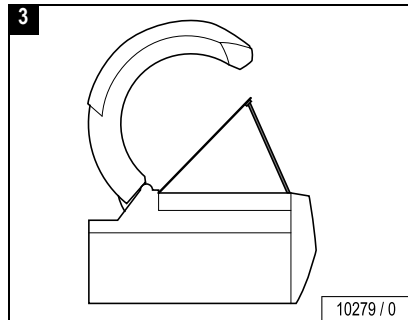
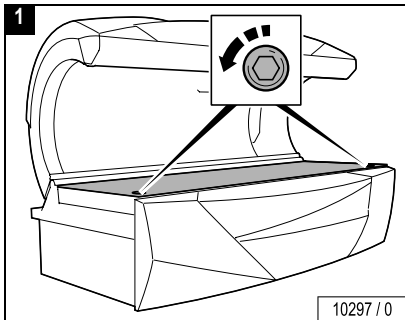
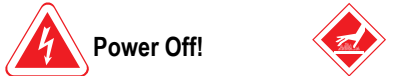
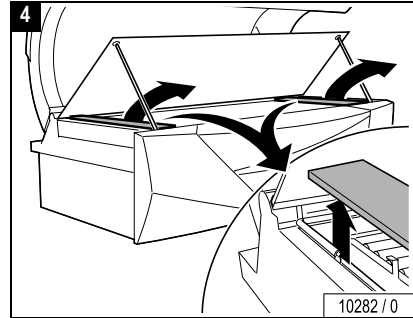
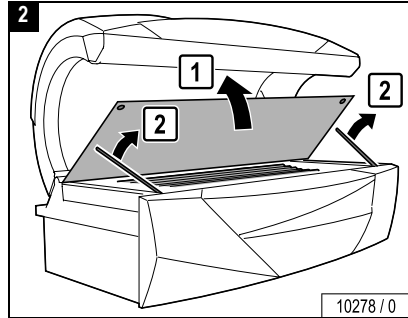
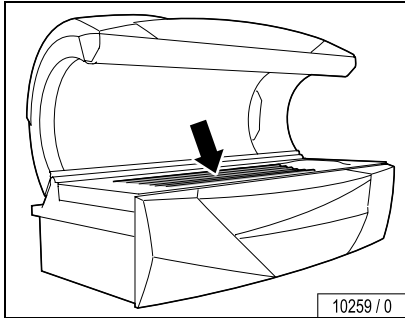
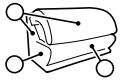

...

Cleaning/replacing UV low-pressure lamps in the sunbed base

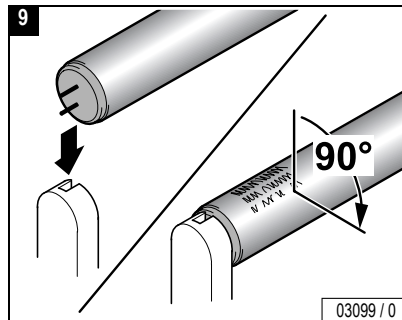
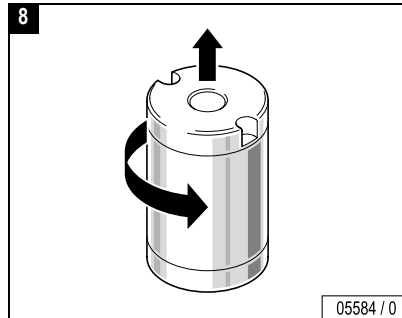
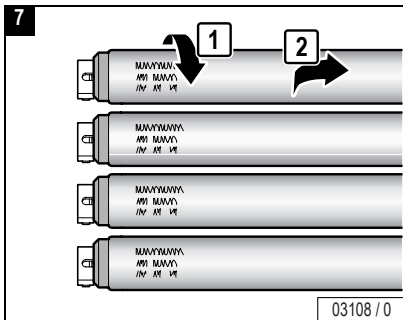
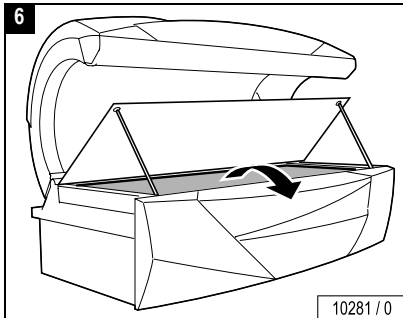

Caution!

Soiling on the panes is burned in by the hot lamps and results in unserviceable panes in the long term.

- Remove fingerprints and other soiling carefully.

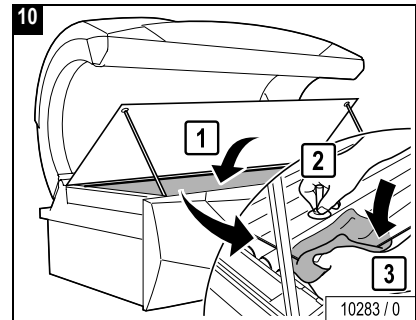

...

Cleaning/replacing UV low-pressure lamps in the sunbed base

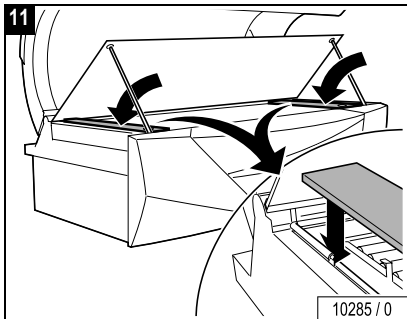

Close:

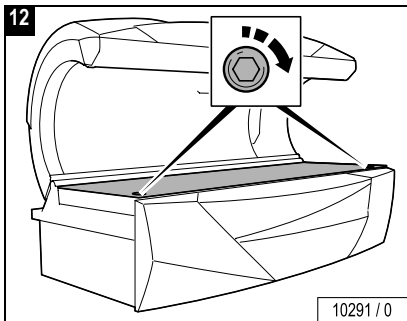

Cleaning/replacing UV low-pressure lamps in the canopy

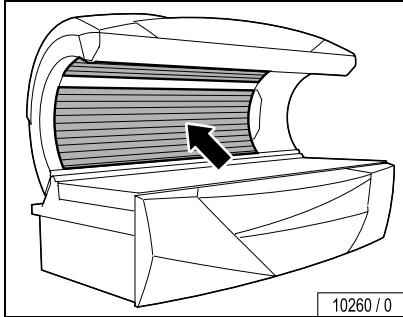
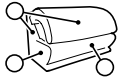

10260 / 0



WARNING!

Danger of injury from the canopy panel!

The canopy panel is heavy and falls down by itself after unscrewing the 3 screws.

- Support canopy panel.
- Loosen screws in the specified order.



Caution!

Canopy panel may break if allowed to fall or if pressure is exerted on the reverse side of an open canopy. Such failure is not covered by manufacturer's warranty.



Power Off!

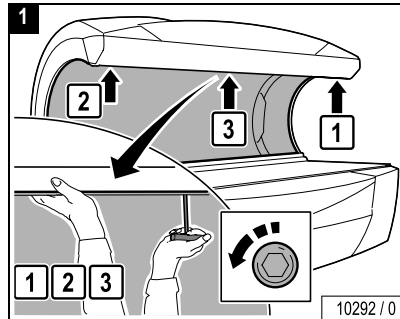

10292 / 0

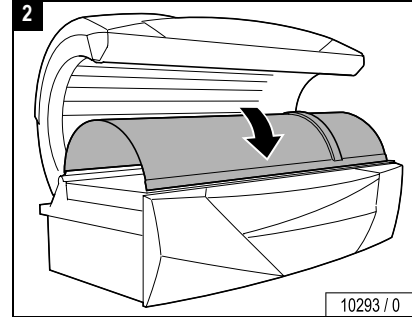

10293 / 0

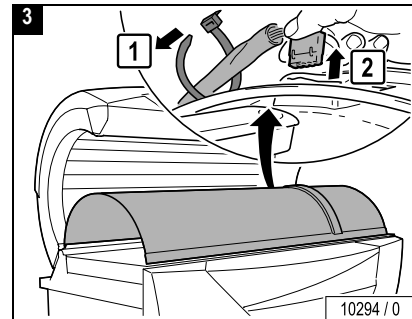

10294 / 0



...

Cleaning/replacing UV low-pressure lamps in the canopy

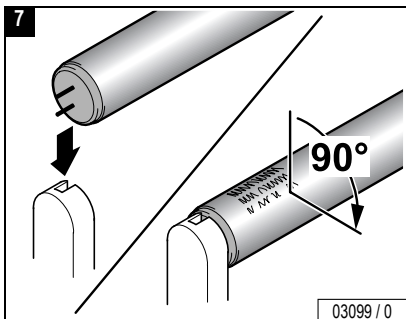
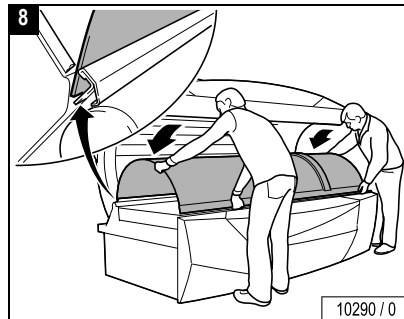
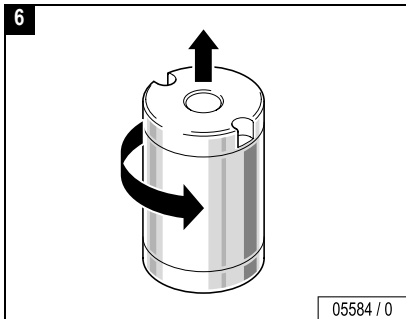
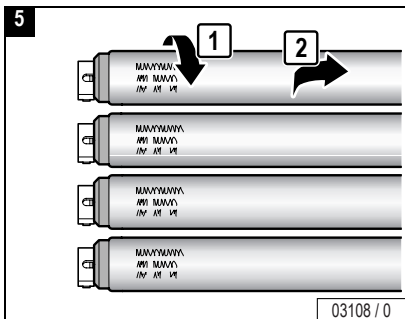
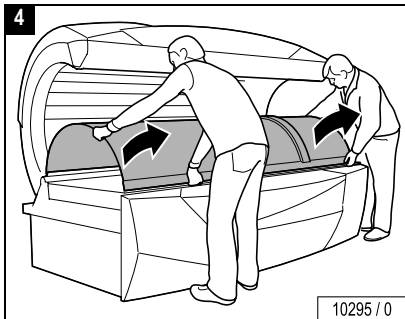

Caution!

- Do not pinch or kink the cable – see Fig. 9!

...

Cleaning/replacing UV low-pressure lamps in the canopy

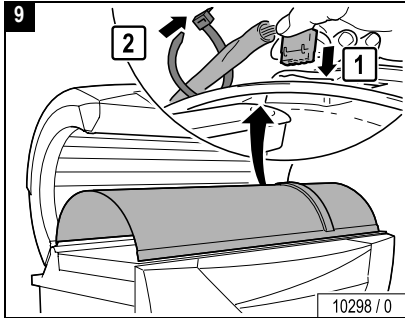

Close:

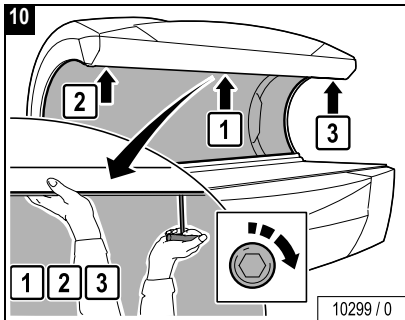

Cleaning/replacing interior lighting

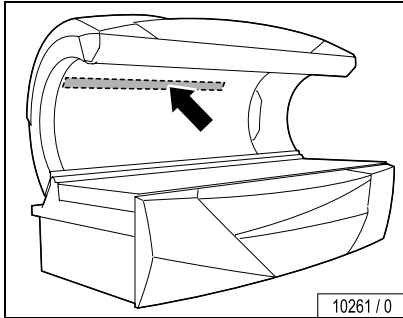
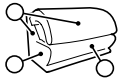

Danger of injury from the canopy panel!

The canopy panel is heavy and falls down by itself after unscrewing the 3 screws.

WARNING!

- Support canopy panel.
- Loosen screws in the specified order.



Caution!

Canopy panel may break if allowed to fall or if pressure is exerted on the reverse side of an open canopy. Such failure is not covered by manufacturer's warranty.



Power Off!

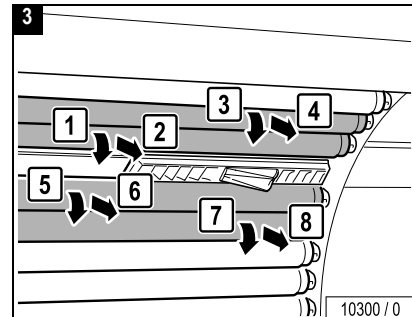
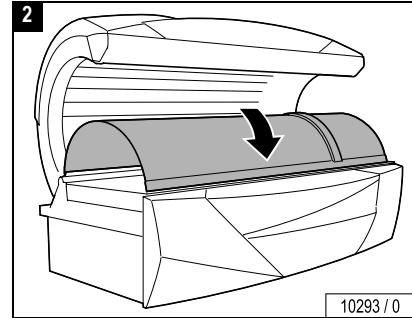
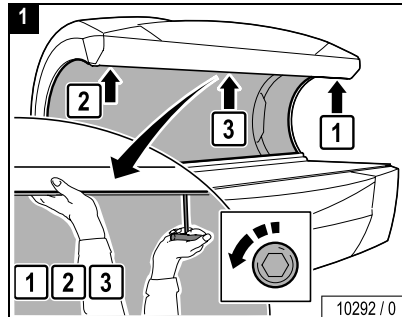

...

Cleaning/replacing interior lighting

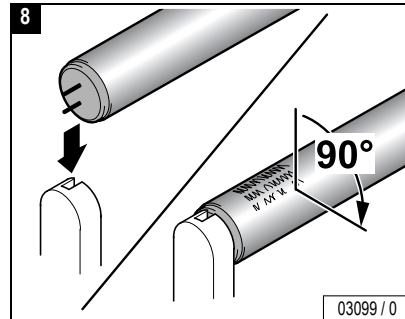
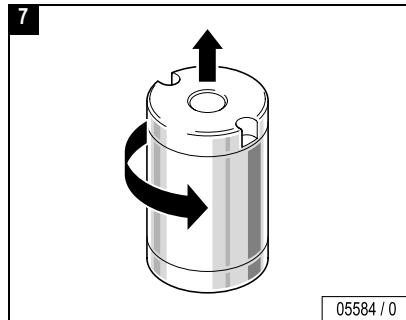
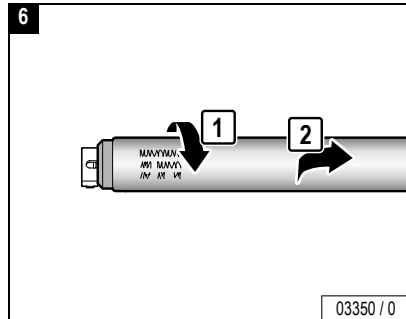
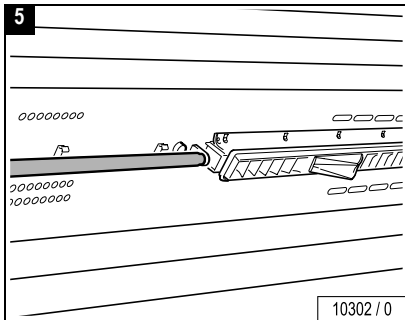
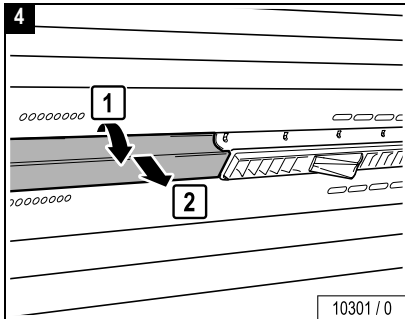

...

Cleaning/replacing interior lighting

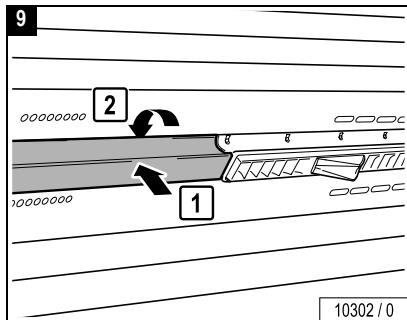

Close:

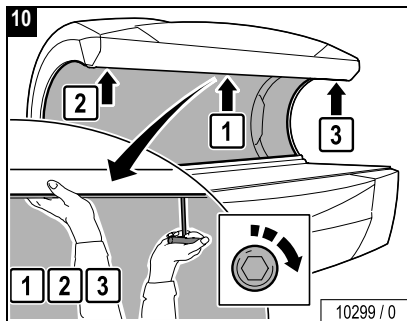

Cleaning or replacing UV high-pressure lamps and filter panels in the canopy

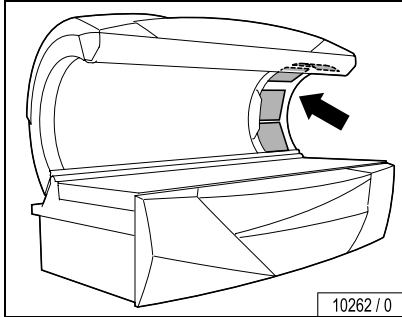
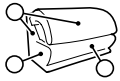

Danger of injury from the canopy panel!

The canopy panel is heavy and falls down by itself after unscrewing the 3 screws.

WARNING!

- Support canopy panel.
- Loosen screws in the specified order.



Caution!

Canopy panel may break if allowed to fall or if pressure is exerted on the reverse side of an open canopy. Such failure is not covered by manufacturer's warranty.



Power Off!

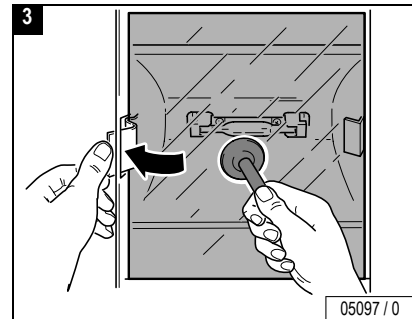
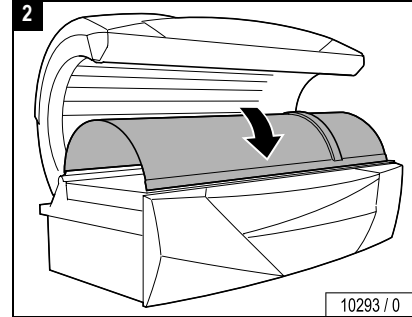
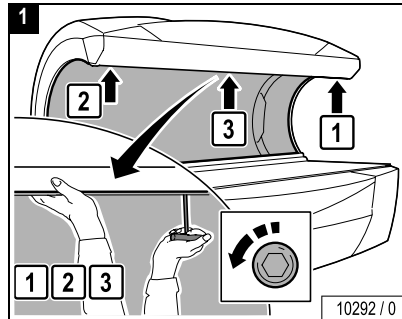

...

Cleaning or replacing UV high-pressure lamps and filter panels in the canopy

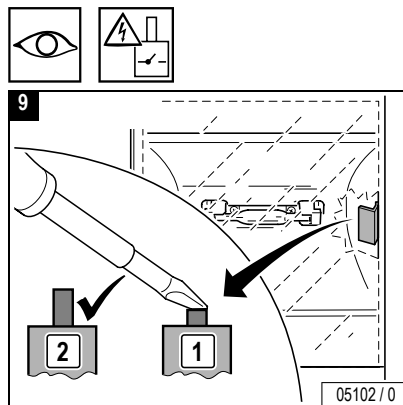
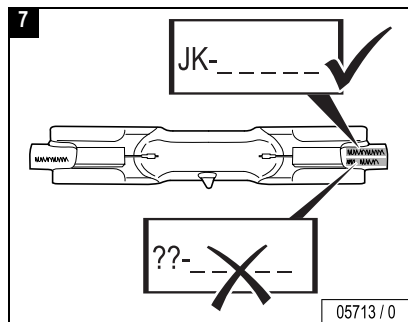
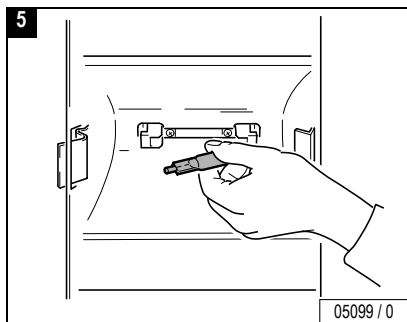
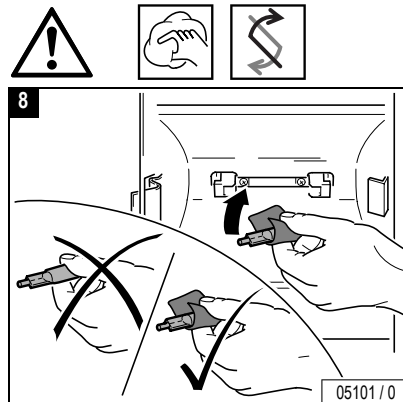
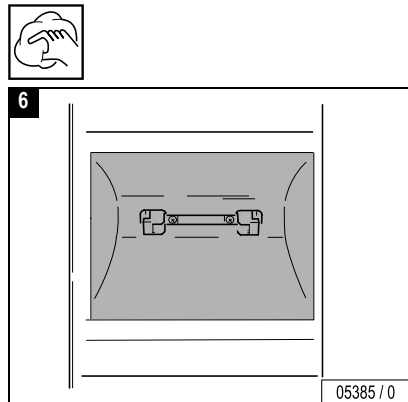
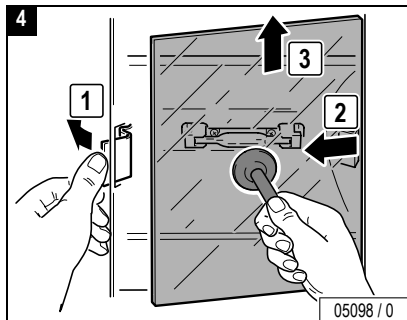

...

Cleaning or replacing UV high-pressure lamps and filter panels in the canopy

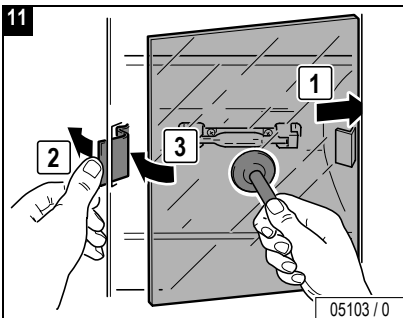
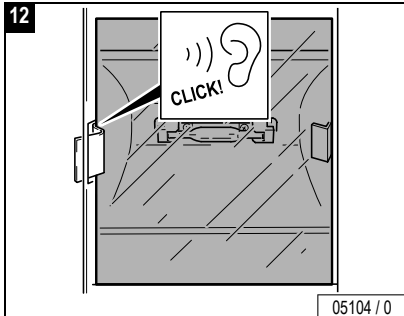
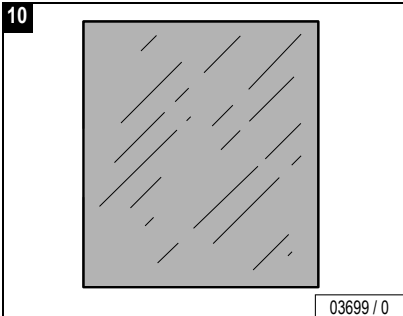

Close:

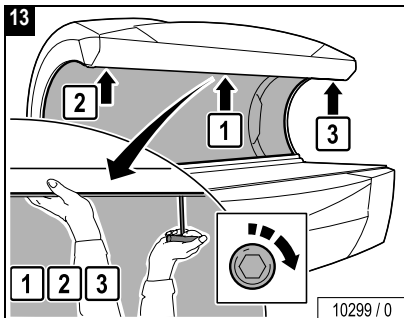

Cleaning/replacing accent light in front panel

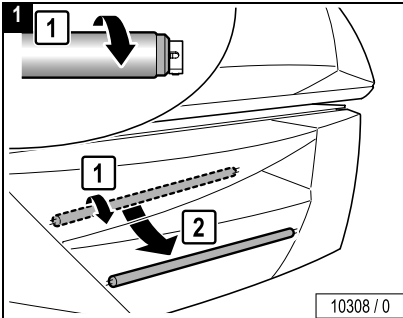
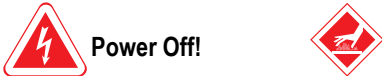
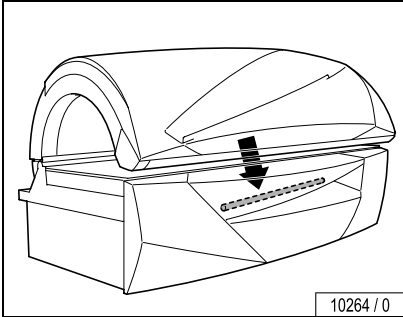
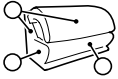

Design Solid Silver

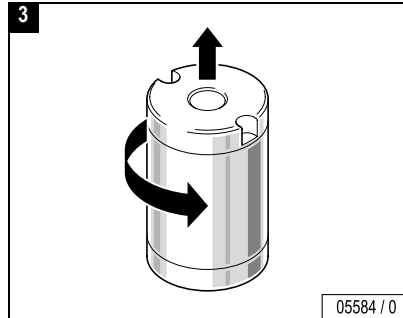
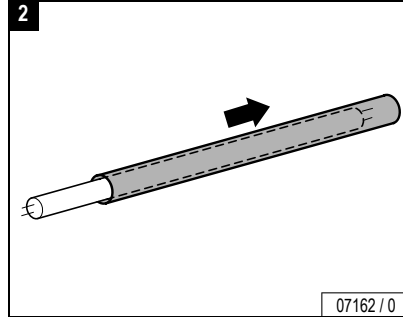

Design Solid Silver

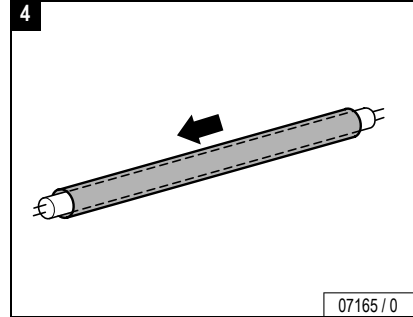

...

Cleaning/replacing accent light in front panel

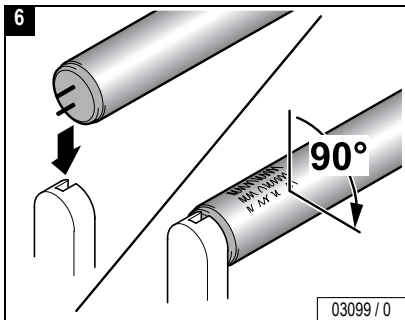
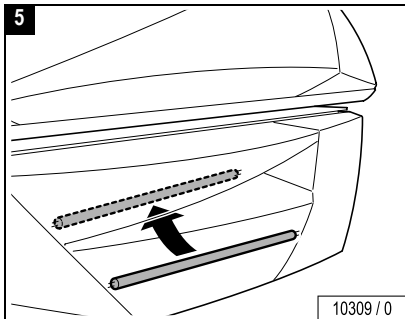

Cleaning the base filters

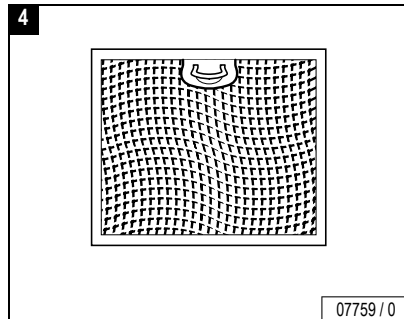
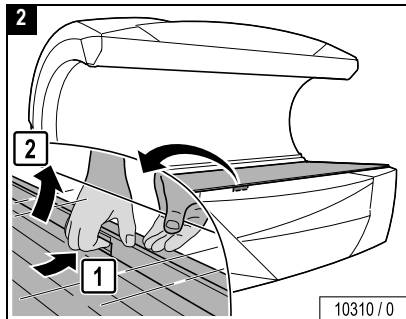
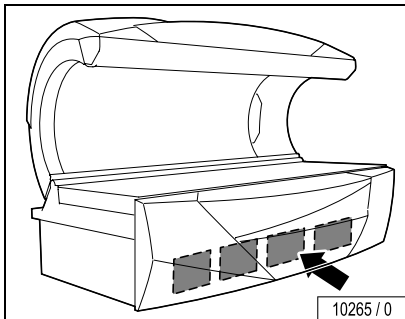
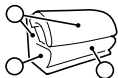

Power Off!

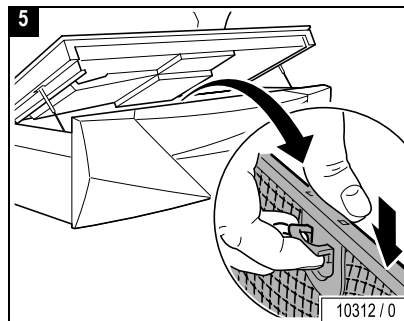
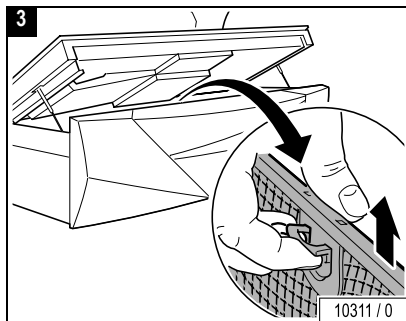
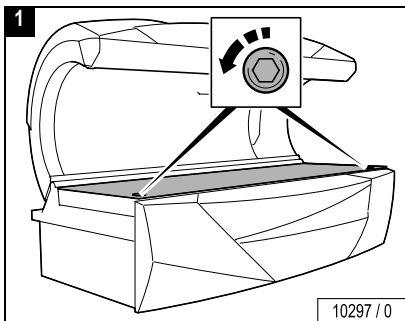

Cleaning the base filters

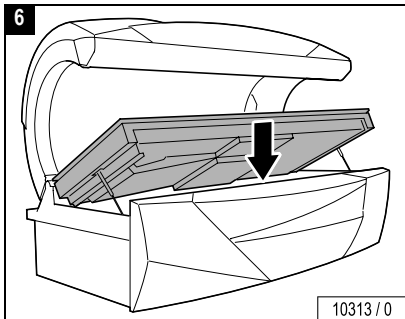

Close:

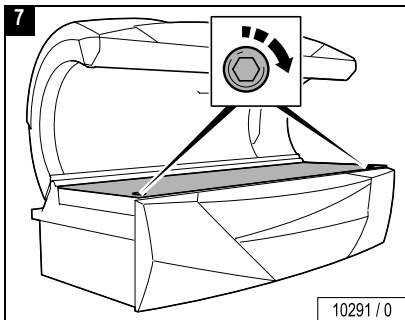

Air condition: Emptying the condensation tank and cleaning the filter



Regelmäßige Sichtprüfung!
Regular visual check!
Contrôle visuel régulier!
Regular visual check!

Gefahr von Geräteschäden!
Risk of damage to equipment!
Risque de détérioration de l'appareil!
Risk of deterioration of the apparatus!

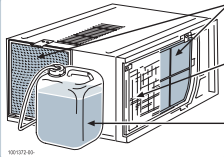

Filtermatten reinigen!
Renew filter mats!
Nettoyer les mats filtrants!

Kühlrippen reinigen!
Clean cooling fins!
Nettoyer les barres de refroidissement!

Kondensatbehälter entleeren!
Empty condensation container!
Vidanger le réservoir à condensation!

10272/0

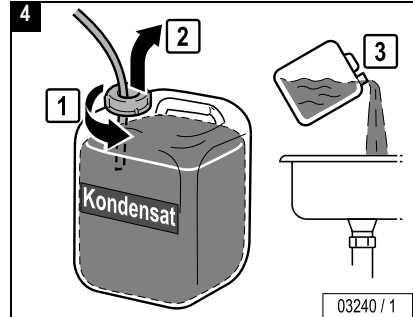
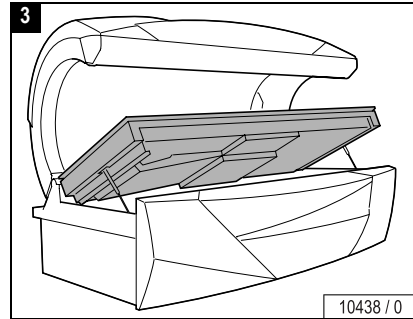
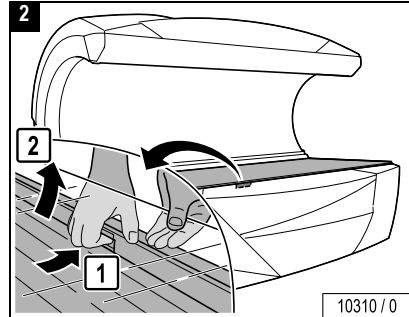
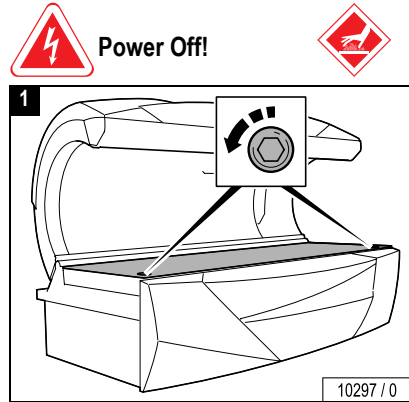
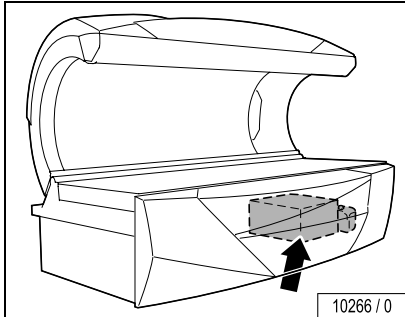
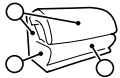

...

Air condition: Emptying the condensation tank and cleaning the filter

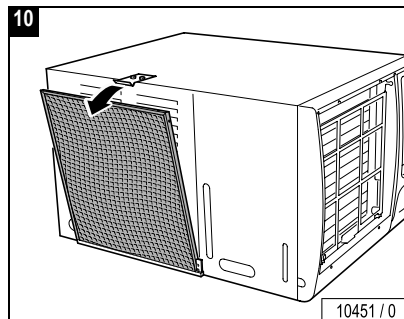
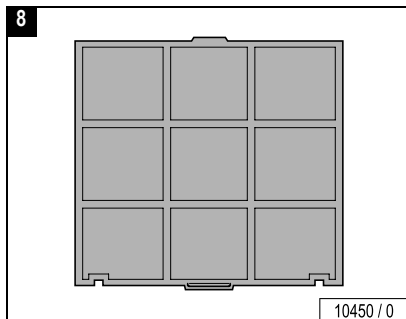
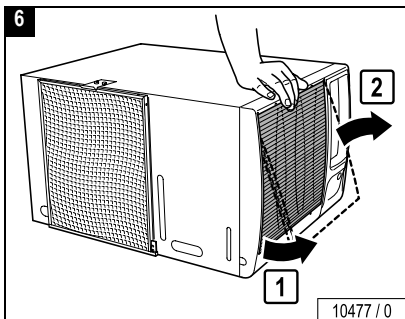
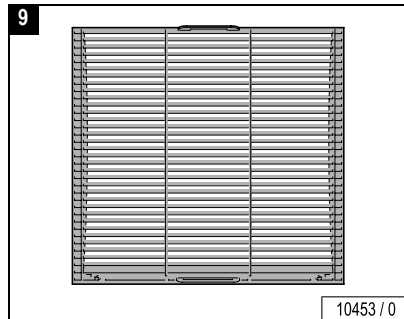
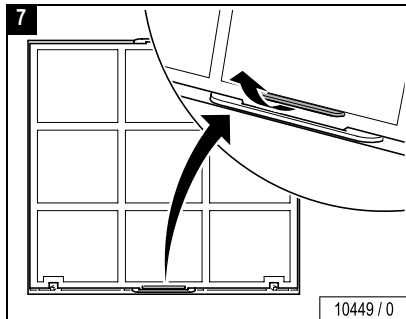
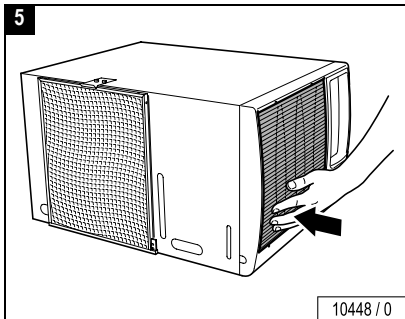

...

Air condition: Emptying the condensation tank and cleaning the filter



11

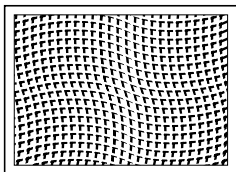

03319 / 0



12

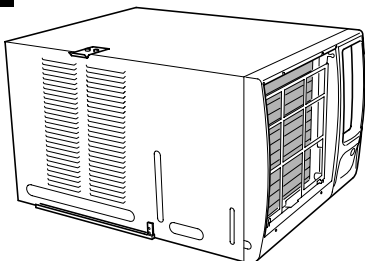

10459 / 0



13

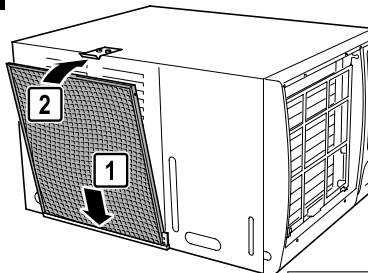

10452 / 0



14

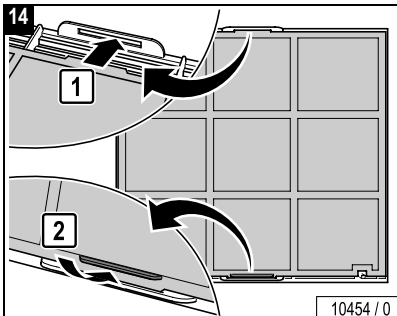

10454 / 0

15

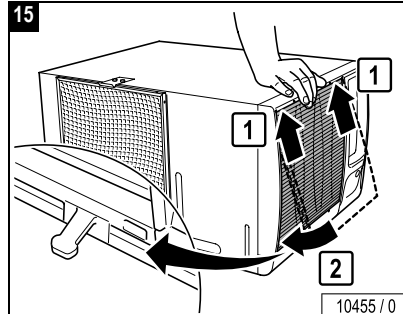

10455 / 0

...

Air condition: Emptying the condensation tank and cleaning the filter

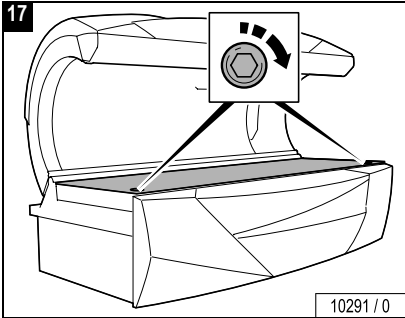
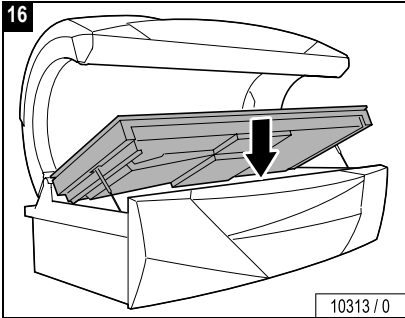

Replacing the AROMA tank

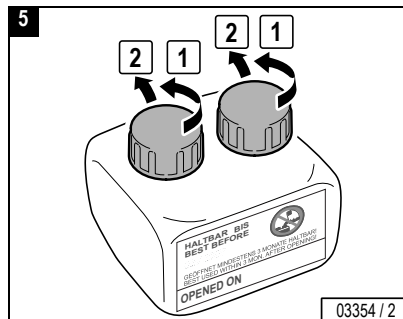
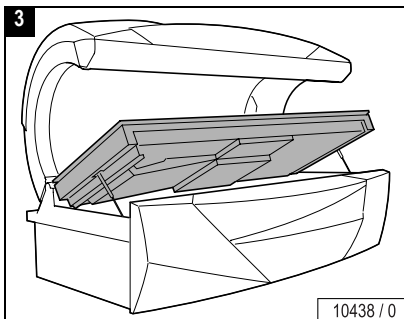
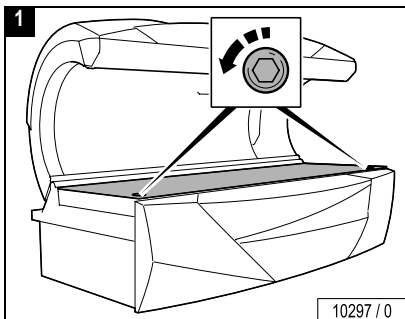
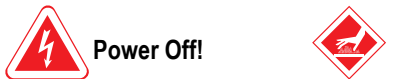
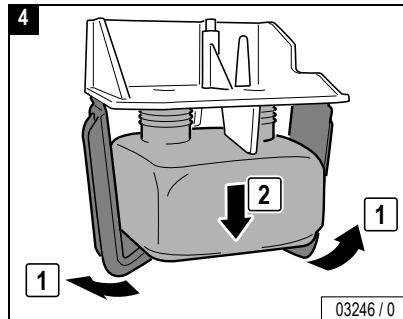
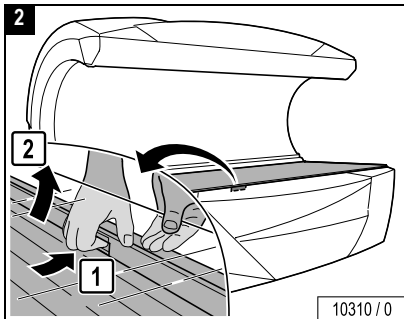
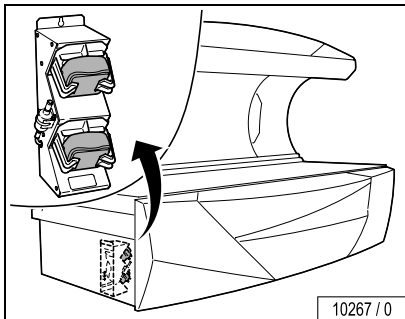
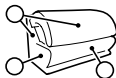

...

Replacing the AROMA tank

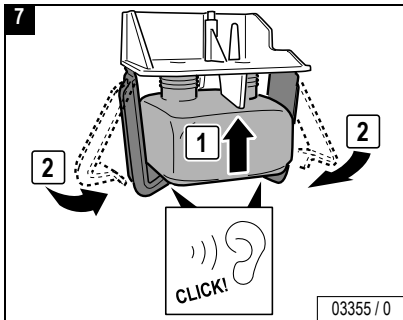
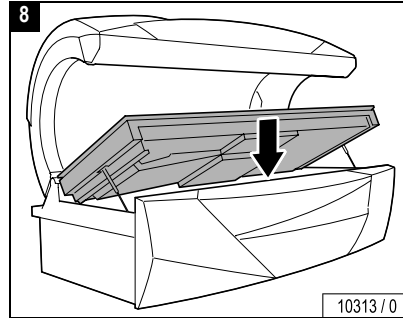
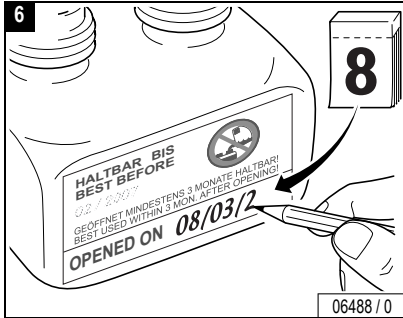

Close:

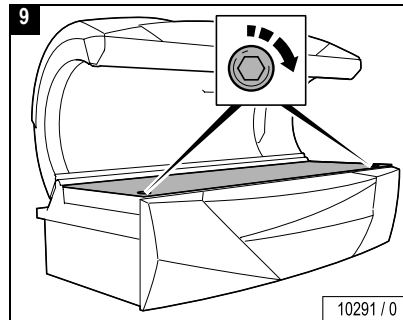

AQUA MIST system: Replacing the canister

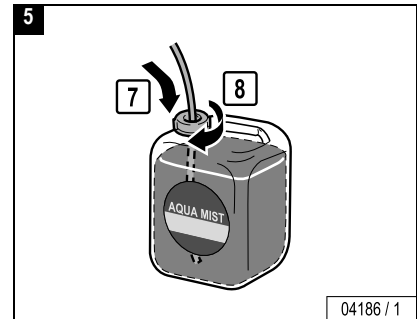
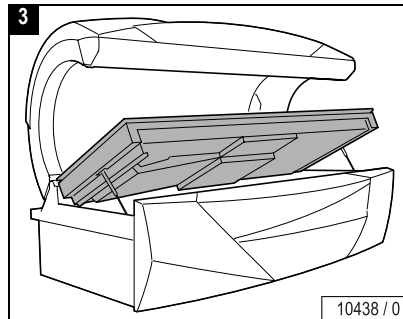
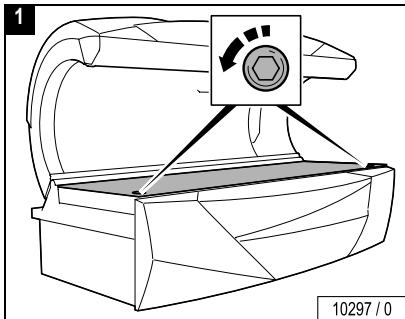
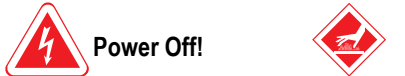
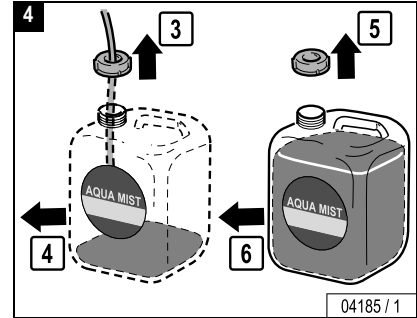
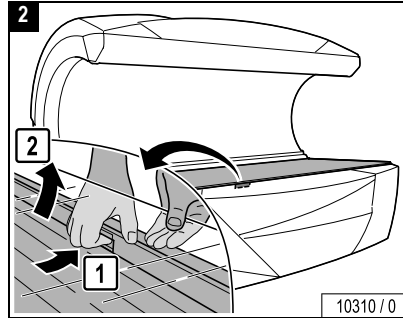
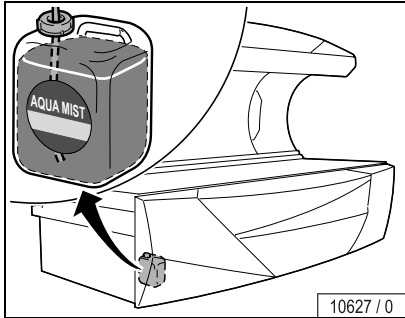
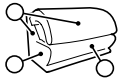

...

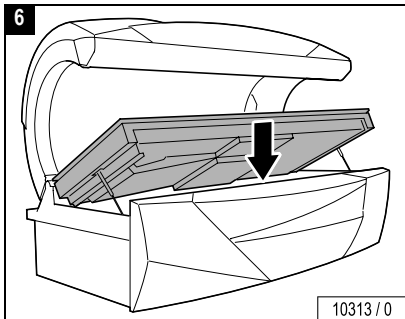

Close:

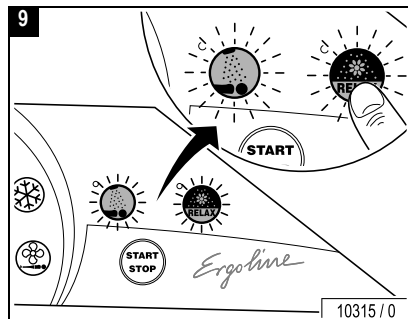
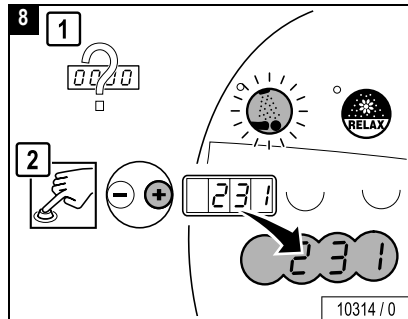
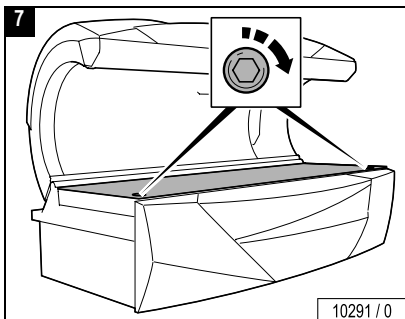

Note:



After replacing the canister, the system must be vented. To do this change to service mode and select function 231 (see separate instructions "Presettings", Order number 1001971).

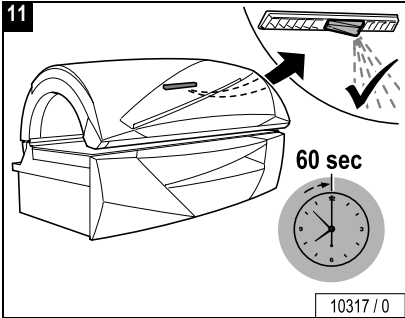
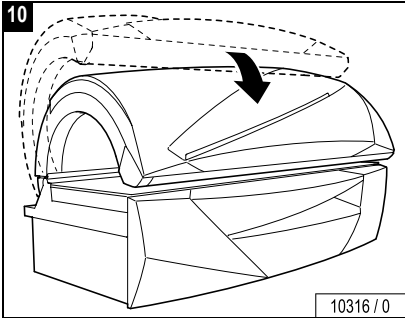

...



Connected load, power and noise level

Model:	Inspiration 400 Turbo Power	Inspiration 450 Turbo Power
Rated power consumption without air condition: with air condition:	9,400 W 10,400 W	– 11,500 W
Rated frequency:	60 Hz	
Rated voltage:	230 V	
Fuse rating:	40 amp 3-pole or 80 amp 2-pole	
Conformity mark:		
Noise level at 1 m from the sunbed:	68.1 dB(A)	66.4 dB(A)
Noise level in sunbed: 	<81 dB(A)	

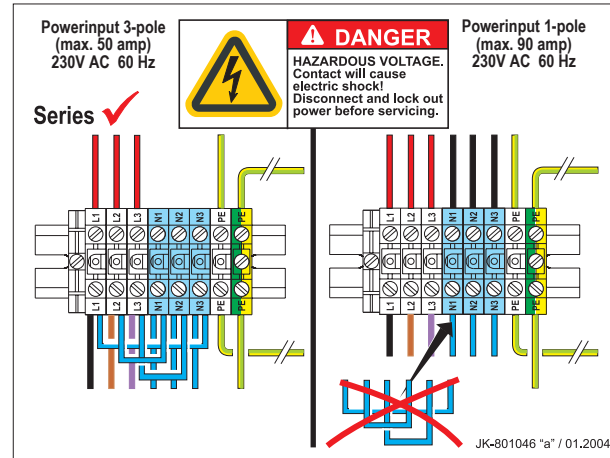

04045 / 1



Rated power, activation and power levels of the UV lamps

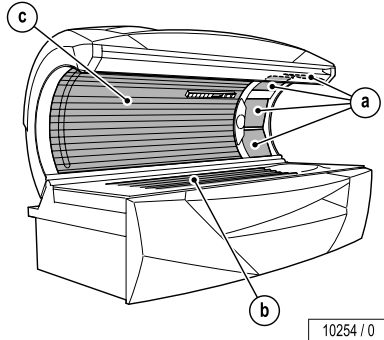

		Rated power	Activation / power levels
Inspiration 400 Turbo Power			
a)		400 W	400 W / 240 W / 120 W
b)		180 W	180 W
c)		160 W	160 W
Inspiration 450 Turbo Power			
a)		400 W	400 W / 240 W / 120 W
b)		180 W	180 W
c)		160 W	160 W

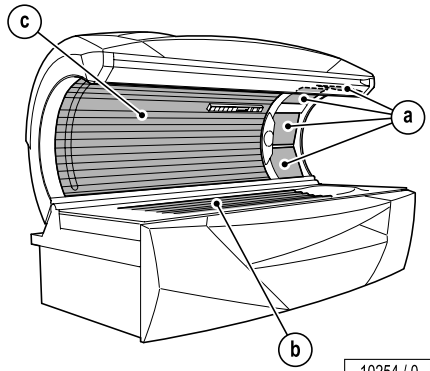

Installed lamps

UV lamps, starters, filter panels	Order No. and lamp name	Inspiration 400 Turbo Power	Inspiration 450 Turbo Power
	Low pressure lamps		
	c) 1005340-.. Ergoline VHP12 160 W	22	26
	b) 1005338-.. Ergoline VHP12 180 W	16	16
	Starter		
	10002-.. Starter S12 (b, c)	38	42
	High pressure lamps and filter panels		
	a) F100723-.. JK Ergoline 400 W	3	4
	a) 1005413-..	3	4







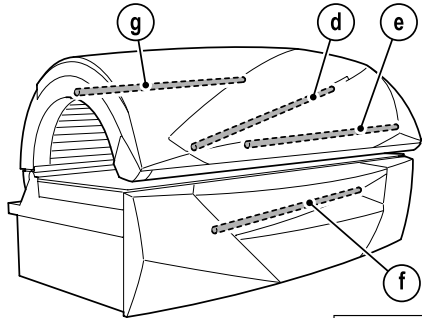

Accent lights

Design Solid Silver



10255 / 0







Standard lamps

d)	1 x		yellow	36 W	1005095-..
e)	1 x		red	36 W	1002112-..
	1 x		Makrolon tube yellow		1500708-..
f)	1 x		red	36 W	1002112-..
	1 x		Makrolon tube yellow		1500708-..
g)	1 x		blue	36 W	11792-..

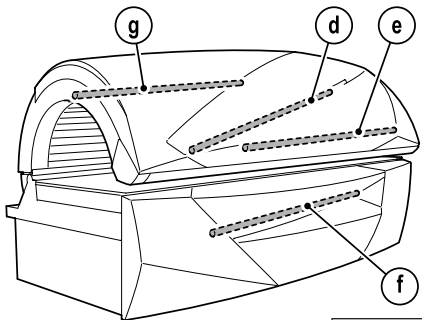
Starter

d) e) f) g)	4 x		S10		10047-..
-------------	-----	---	-----	--	----------



Accent lights	Design Sky Blue			
 <div data-bbox="518 588 622 621" style="border: 1px solid black; padding: 2px; width: fit-content; margin-left: auto;">10255 / 0</div>	Standard lamps			
	d) 1 x	 blue	36 W	11792-..
	e) 1 x	 blue	36 W	11792-..
	f) 1 x	 blue	36 W	11792-..
	g) 1 x	 blue	36 W	11792-..
Starter				
d) e) f) g)	4 x  S10		10047-..	



Spare parts and accessories

Filter, AQUA MIST, AROMA

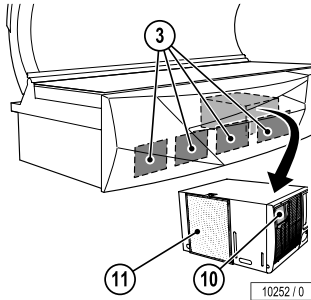

- ③ 4 x 52104-..
- ⑩ 1 x -
- ⑪ 1 x 51937-..

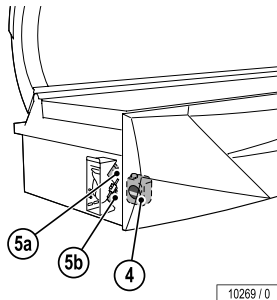

- ④ 1 x 3652603-..

AQUA MIST, 6000 ml

- ⑤ a) 3652003-..
- b) 3652203-..

AROMA, 100ml

- a) Relax
- b) Cabin

Acrylic glass, fan

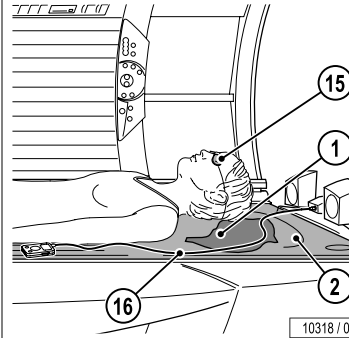

- ② 1x 1003696-..
- ① 1x 1501870-..

- ⑮ 1x Ergoline 84592-..
- or Schmerler 2255
- ⑯ 1x 1001855-..

Dimensions

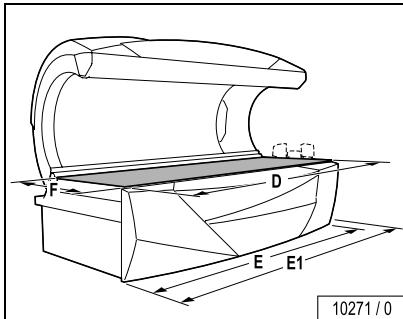
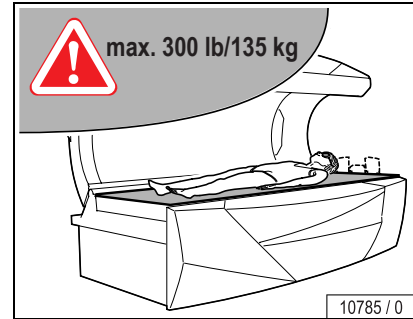
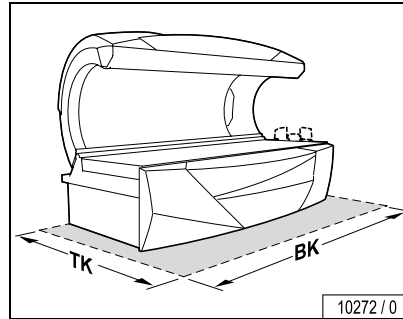
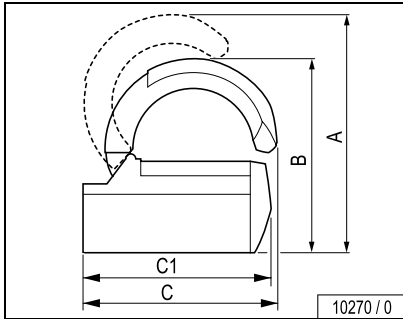

A =	64 in	1,625 mm
B =	51 5/16 in	1,304 mm
C =	56 1/4 in	1,428 mm
C1 =	55 5/16 in	1,421 mm
D =	88 9/16 in	2,250 mm
E =	89 3/8 in	2,270 mm
E1 =	93 5/16 in	2,370 mm
F =	32 11/16 in	830 mm
TK =	82 11/16 in	2,100 mm
BK =	94 1/2 in	2,400 mm



Installation location

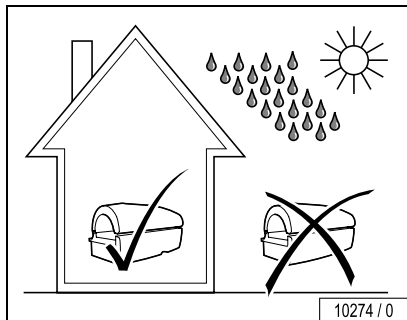
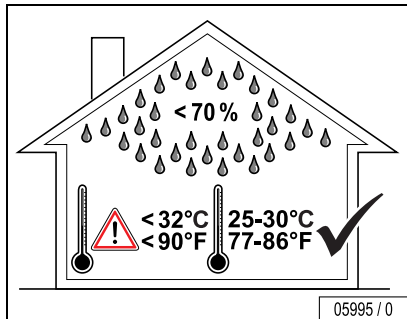

Ventilation

Attention! Danger of failure!



Non-observance of the ventilation information in the Ergoline Planning Manual can lead to serious system malfunctions.

Data for air supply and extraction planning can be found in the Ergoline Planning manual¹⁾ (www.sunergoline.de). You can also ask for this data from your sales agent or customer service (see Page 2).

Operating altitude

For altitudes greater than 2000 m above sea level a conversion must be carried out to ensure trouble-free operation. Please contact Customer Service (see Page 2) before carrying out the conversion and starting up the unit for the first time.

1) Order no. 801482

JK-Products, Inc. – Limited Warranty

JK-Products, Inc. warrants its products to be free from defects in materials and workmanship under intended normal use as described in the unit's Operation and Instruction Manual, for a period of three (3) years from date of sale.

This Limited Warranty applies only to the original purchaser of the equipment through JK-Products, Inc. or its authorized dealer or distributor, and is not transferable.

Global Service USA obligations under this warranty are limited to repair or replacement of any defective part without charge for that part to the original purchaser, with the following exceptions:

- A Fluorescent lamps are warranted against defects for a period of thirty (30) days from date of sale.
- B Only parts obtained through JK-Products, Inc., its authorized dealers or distributors may be used. Transportation costs for parts shipped to the consumer and the return of defective parts to Global Service USA are not included.
- C Labor will be furnished without charge for ninety (90) days from date of purchase only. All labor and related charges must be authorized by Global Service USA prior to start of repairs, and must coincide with Global Service USA established rates and time allotment policy.
- D Acrylic: Refer to Manufacturer's Acrylic Warranty Policy.

It is imperative that the original customer completes and returns the enclosed warranty card within 10 days after purchase to insure valid registration and coverage for potential claims.

If the warranty card is not registered, proof of purchase from JK-Products, Inc. or its authorized dealer or distributor will be required prior to any consideration on warranty claims. This could result in service delays.

This warranty is extended to the individual or legal entity, whose name appears on the warranty registration card filed with Global Service USA, or whose name appears on the original sale document and may not be transferred to any other individual or legal entity.

This warranty does not apply to any failure of the product, or any parts of the product due to alterations, modifications, misuse, abuse, accident, improper maintenance, improper installation, acts of God or if the serial number on the product has been removed, altered or defaced. Adequate packaging must be used for returned goods to prevent freight damage.

There are no warranties which extend beyond the description on the face hereof. There is no express or implied warranty of fitness of merchantability.

The remedies provided in this limited warranty are the exclusive remedies provided to the purchaser by Global Service USA and are provided in substitution of all other remedies. Consequential and incidental damages are excluded.

No person, firm or corporation is authorized to obligate JK-Products, Inc. for any liability in connection with the sale or use of these goods.



Limited Acrylic Warranty

JK Products, Inc. warrants its acrylic sheets to be free from defects in material and workmanship, under intended normal use, for a period of one (1) year from date of sale of the tanning bed. Due to the tanning lotions, cosmetics, disinfectant and improper cleaners used on tanning surfaces that cannot be controlled by JK Products, Inc., after the first thirty (30) days of warranty period acrylic will be subject to a prorated cost to the consumer.

JK Products, Inc. obligations do not include transportation charges on replacement acrylic.

JK Products, Inc. assumes no liability for the cost of removing defective sheets or installing replacement sheets, nor for damage to persons or property.

To make a claim, contact an authorized dealer or distributor of JK-Products, Inc. or Global Service USA with the model number, the serial number, and the date of purchase of the bed in which the acrylic will be used.

There are no warranties which extend beyond the description on the face hereof. There is no express or implied warranty of fitness or merchantability.

The remedies provided in this limited warranty are the exclusive remedies provided to the purchaser by Global Service USA and are provided in substitution of all other remedies. Consequential and incidental damages are excluded.

Global Service USA

A Div of JK Products & Services, Inc.
#1 Walter Kratz Drive
Jonesboro, AR 72401

☎ 800-445-0624

☎ 870-935-9046

e-mail: support@jkamerica.com

<http://support.jkamerica.com>



Warranty Claims

Policy & Procedures

1. When to file a Warranty Claim:

In the event that your tanning system is not functioning properly under intended normal use as described in the unit's Operation an Instruction Manual, you may then have established cause to file a Warranty Claim.



NOTE:

Both the tanning system and legal registered owner must meet the criteria established under JK Products, Inc. Limited Warranty as described in this manual before any Warranty Claim will be considered.

2. Where to call to place a Warranty Claim:

JK-Products, Inc. is supported nationwide by an extensive dealer/distributor network through whom the majority of our units are sold. These dealers/distributors are required by contract to stock sufficient parts to meet the various warranty and nonwarranty needs of their customers.

Therefore, in order for you to properly file a Warranty Claim, you must locate the name and phone number of the dealer/distributor through whom you purchased your unit. Normally this information can be easily located either on your paid invoice or other proof of purchase documentation that you received when taking delivery of the unit.

Next, notify the dealer/distributor of the serial number, model number and date unit was purchased. This will initiate the Warranty Claim process. Upon determination of the problem, your dealer/distributor can then supply you with the part(s) and proper instructions to return your unit to working order.

Each dealer/distributor has their own internal procedure for handling Warranty Claims and credits.



NOTE:

JK-Products, Inc., the manufacturer, does not involve itself in the direct handling of a Warranty Claim except where mitigating circumstances apply and where required by law.



NOTE:

If part returned to Global Service USA proves to be operational and not defective, or if product code numbers on part do not correspond with individual unit date on file with Global Service USA, then a 30% restocking fee will be charged in addition to the retail purchase price of part.

Acknowledgment of the Agreement is not required for acceptance of the foregoing stipulations.

Labor Warranty Claim/Credit Procedures

Global Service USA furnishes labor without charge for a period of 90 days from date of purchase. All labor and related charges must be authorized by Global Service USA prior to start or repairs, and must coincide with Global Service USA established rates and time allotment policy. Please contact our Service Department for authorization and billing procedures.



Limited Lifetime Warranty

Global Service USA warrants specific individual components of the tanning system against defects in materials and workmanship for the life of the product. Coverage is limited to units purchased after November 1, 1994.

This warranty is restricted by the following components only:

- Steel Back Panels
- Structural Steel Frame Components
- Exterior Steel Body.



NOTE:

Components are warranted on an individual basis and not as they may effect the complete product.

Warranty coverage does not include cosmetic abnormalities such as scratches, nicks, dents, rust, oxidation of paint or other cosmetic changes that do not interfere with the designed function of the unit.

This warranty does not include failure of the product due to alteration, modifications, misuse, abuse, improper maintenance, improper installation or repair.

This warranty is not transferable and is only applicable to the original purchaser named on a completed and registered warranty record at JK-Products, Inc. headquarters.

JK Products, Inc. obligations do not include transportation charged on the shipping of new components to the customer or on the return of defective components of the manufacturer. All freight charges must be paid by the customer.

There are no warranties which extend beyond the description on the face hereof. There is no express or implied warranty of fitness or merchantability.

The remedies provided in this limited warranty are the exclusive remedies provided to the purchaser by Global Service USA and are provided in substitution of all other remedies. Consequential and incidental damages are excluded.



NOTE:

Any misuse, abuse, modification, alteration, improper maintenance, improper installation, etc. of this product or its intended use will subject said party to direct responsibility and liabilities for any and all consequences resulting from such action. Furthermore, such actions will void all warranties and may relieve Global Service USA of any liabilities relating to said product.

Index

A		G	
Accent lighting, maintenance.....	76	Glasses	25
Accent lights		Global Service USA, address.....	2
Standard	92	Guidelines	16
Accessories	21		
Acrylic glass panel		I	
Allowable loading	95	Installation location.....	96
Product information	57	Installed lamps	91
Acrylic glass, cleaning	55	Intended use.....	16
Air condition		Interior lighting, maintenance	70
Cleaning the filters	80	Interrupting tanning session	27
Operation	31		
Allergies	25	L	
AQUA MIST AROMA system	57, 94	Lamp configuration.....	91
AQUA MIST canister, replacing.....	86	Lamps, disposal	18
AROMA tank, replacing	84	Listening to Info texts	43
B		M	
Base filter, maintenance	78	Maintenance	54
Base, replacing the UV lamps	64	Maintenance and care	51
Body cooling	33	Safety information.....	63
		Maintenance intervals	58
C		Maintenance overview.....	54
Canopy		Make-up	25
Replacing the UV lamps	67	Malfunctions	53
Canopy, interior lighting.....	70	Medication	25
Care	51	MP3 music, product information.....	17
Channel	45	MP3 player connection.....	39
		Music channel, choosing.....	45
Cleaning	55		
Filter	56		
Lamps, filter panels	56		
Cleaning intervals.....	58		
Connected load.....	89		
Contact lenses	25		
Control elements	23		
D			
Description	20		
Dimensions	95		
Disinfection.....	55		
Disposal of lamps.....	18		
E			
Empty the condensation tank.....	80		
Ending tanning session	27		
Environmental protection	18		
Equipment	19		
Extraction planning.....	96		
F			
Facial tanner			
Operation.....	28		
Replacing high pressure lamps	73		
Filter panels, maintenance	73		
Filter panes	91		
Filter, cleaning intervals	60		
Fin comb	56		

N		Soiling (AQUA MIST)	57
Noise level	89	Spare parts.....	51
O		Order-No.	94
Operating altitude	96	Starter	91
Operation overview	23	Starting tanning.....	26
Operator commitments	16	Sunbed description	20
Order numbers.....	94	Sunbed, how to use it.....	25
P		Switching AQUA MIST on.....	37
Packaging	18	Switching off the sound	48
Plastic surfaces.....	55	Switching on AROMA.....	35
Power.....	89	T	
Power levels of the lamps.....	90	Tanning	25
Power, switching off.....	52	Tanning instructions.....	25
Preparation time	26	Technical data.....	89
Proper use	16	Temperature, regulating.....	31
Protective goggles	25, 26	Timer.....	26
R		U	
Rated power of the lamps.....	90	Using the sunbed	25
Relamping.....	63	UV low pressure lamps	
Running time of accent lighting.....	50	replacing.....	64, 67
S		V	
Safety information, maintenance	63	Ventilation data, see Planning Manual.....	96
Selecting audio system	45	Voice Guide.....	41
Showering.....	25	Volume.....	48
Skin sensitivity	25		
Skin types	3		



NO POSTAGE
NECESSARY
IF MAILED
IN THE
UNITED STATES

BUSINESS REPLY MAIL
FIRST-CLASS MAIL PERMIT NO 295 JONESBORO AR

POSTAGE WILL BE PAID BY THE ADDRESSEE

JK PRODUCTS & SERVICES, INC.
#1 WALTER KRATZ DRIVE
JONESBORO, AR 72401

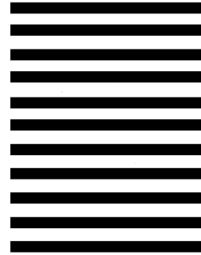

Separate here



SUN | **DASH**
PERFORMANCE | TANNING

soltron

Ergoline

Ⓐ WARRANTY REGISTRATION

Please complete the warranty section below. To validate and insure proper coverage, card must be completed and returned within ten (10) days of the date of purchase.

_____/_____/_____
Name of Purchaser Date of Purchase

Street Address or P. O. Box

City State Zip

()

Phone Number with area code

Company unit purchased from and amount paid.

Name of Business (if applicable)

E-mail

Circle Answers:

Type of Business:

Tanning Salon Video Store Health Club Beauty Salon

Other _____

Number of tanning beds at this location:

1-3 4-7 8-15 16-25 >25

If you experience any difficulties obtaining replacement parts from your distributor, please call Sun Ergoline at 800-643-0086, choose option 5.

Year & Model #

Serial #

SUN ERGOLINE, A DIVISION OF JK-PRODUCTS & SERVICES, INC.

1 Walter Kratz Drive · Jonesboro, AR 72401

Phone: 800.643.0086 (Toll-free) · Email: ergoline@sunergoline.com

Fax: 870.935.3618 · Website: www.sunergoline.com



1004003